

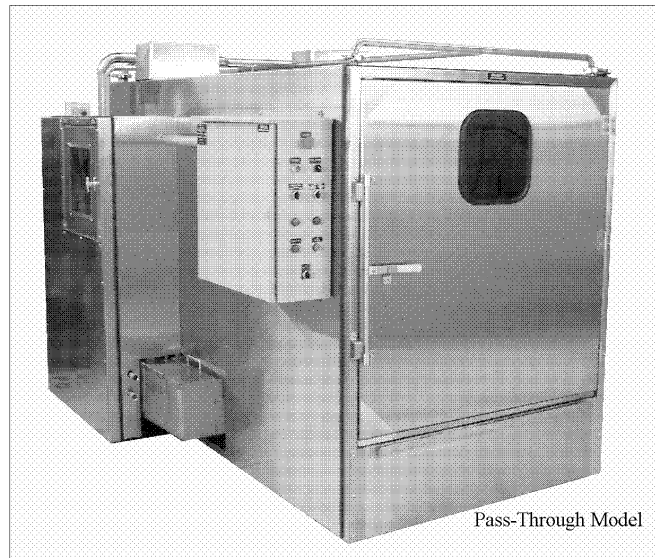

Operating Manual

AQ-4000 Series



Pass-Through Model

**READ ALL MATERIAL
PRIOR TO OPERATION**

AQUA PHASE AQ-4000 Series Operating Manual

Contents

Description	Page		Description	
Caution Notices	2		Other Supplied Information:	
Reference Diagrams	3-5		Troubleshooting Guide	
Control Panel Switches & Functions	6		Servicing Procedures Guide	
Operating Information	7		De-Liming Instructions	
Set-up Procedures	7-8		Warranty Information	
Daily Start-up & Shut Procedures	9		Logic Wire Diagram	
Daily Operating Procedures	10		Technical Data for Valves	
Wash Sequence Description	10		Permanent Water Line Installation	
Adjustments & Maintenance	11			
Disinfectant Appl System (optional)	12			
Controller (PLC) Electronics Diagram	13			
Controller (PLC) Display Messages	14-15			
Fuses	16			

Supply List

The following items are required for the operation of your *Aqua Phase* machine:

1. **Two ten foot hoses, rated at 150° F or higher, are supplied.**
 - These hoses are used for the filling and draining functions of the machine. Do not use standard garden hoses. **25' hoses are available at an additional charge from Aqua Phase.**
 - **Note:** The longer the hose, the more time it will take for the fill and the drain operations. It is not recommended to use hoses longer than **50 feet**.

2. **A 240 Volt electrical circuit.**

For added safety, it is **recommended** to use a ground fault receptacle at the power source where the machine will be plugged in.

AQUA PHASE AQ-4000 Series Operating Manual

Aqua Phase Caution Notices

In addition to the warnings and cautions provided throughout this manual, please observe the following:

- DO:** **Read this operations manual and follow all instructions.**

- DO NOT:** Operate the machine without all the filter screens in place.
- DO NOT:** Climb into the Wash Chamber.
- DO NOT:** Wash any item with unsealed electrical components.
- DO NOT:** Perform any type of service operation unless the machine is unplugged.
- DO NOT:** Use an extension cord between the wall outlet and the machine.
- DO NOT:** Try to modify the machine in any manner without factory approval.
- DO NOT:** Operate the machine in high foot traffic areas.
- DO NOT:** Use garden hoses for the fill and drain hoses.
- DO NOT:** Operate the machine unless you have been properly trained to run the machine.

- DO:** **Call your dealer, sales representative, or the factory with any questions, need for more information, or to order supplies for your *Aqua Phase Washer*.**

Aqua Phase carries a complete line of supplies and parts and a variety of cleaning, rinse, and disinfectant solutions specifically formulated and chosen to work with your *Aqua Phase* machine. You may order your solutions, supplies, or parts by calling your dealer or *Aqua Phase* at 800-208-9274.

AQUA PHASE AQ-4000 Series Operating Manual

General Information

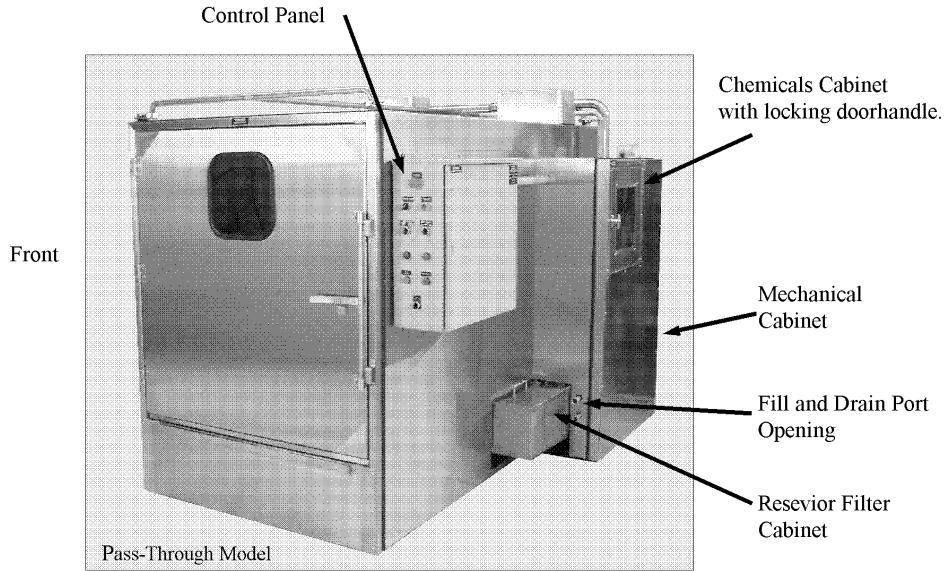

Main Interior Components

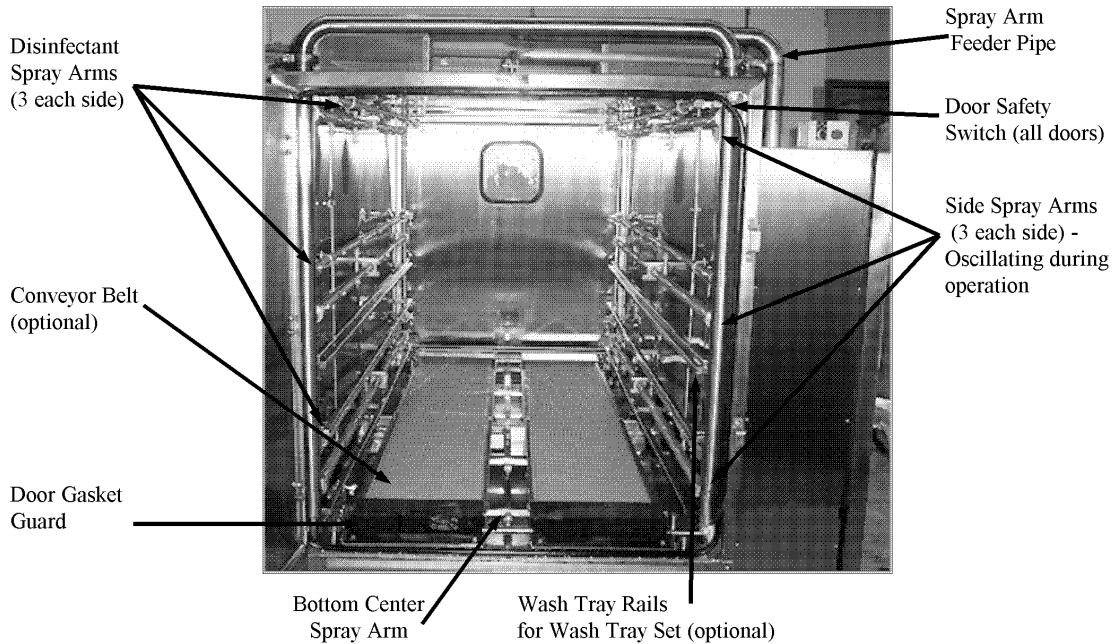

AQUA PHASE AQ-4000 Series Operating Manual

Mechanical Components (Including Optional Devices)

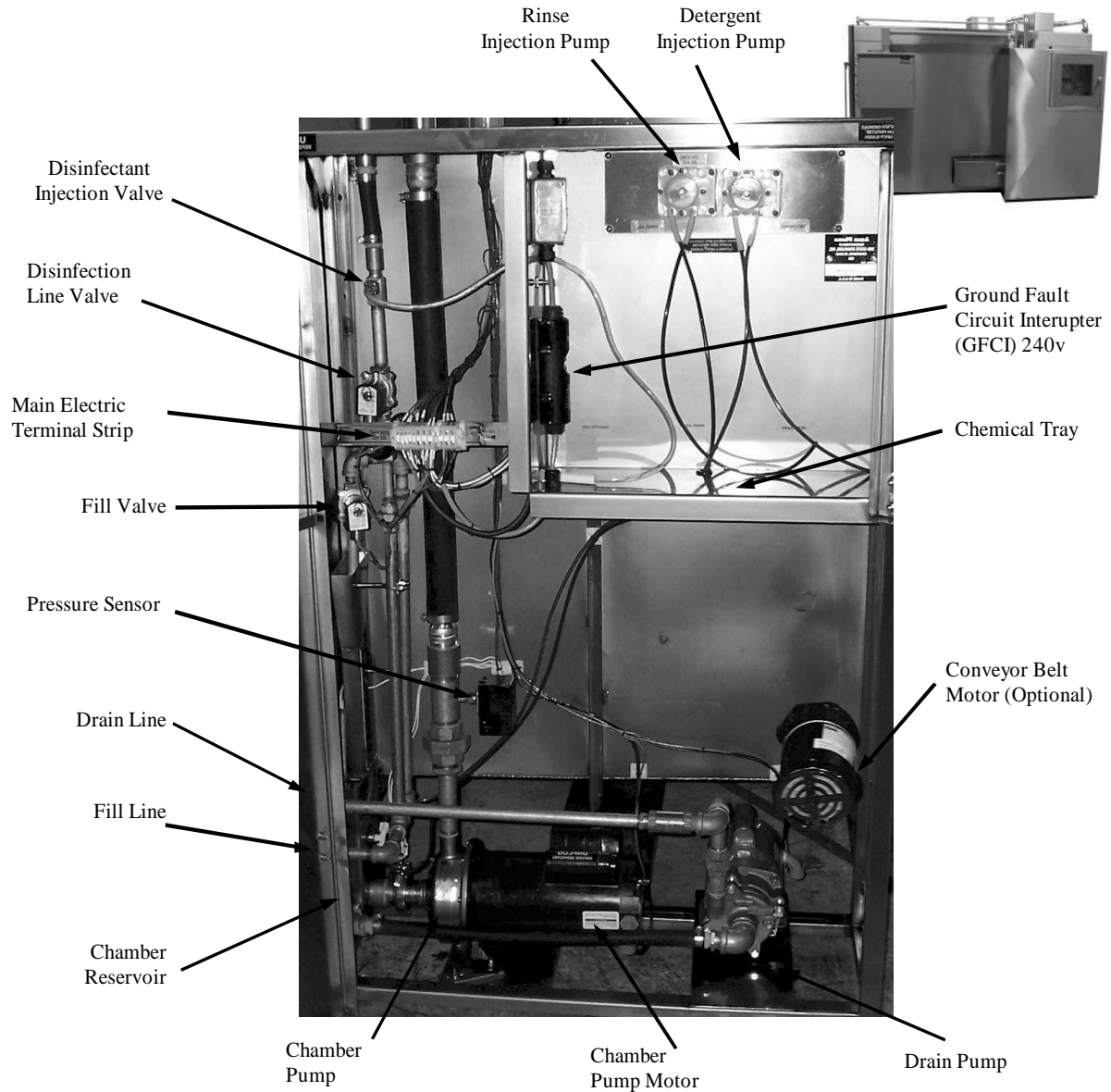

AQUA PHASE AQ-4000 Series Operating Manual

Filter Screen

Filter Screen that needs to be cleaned when low pressure indicator light is blinking on the control panel face.

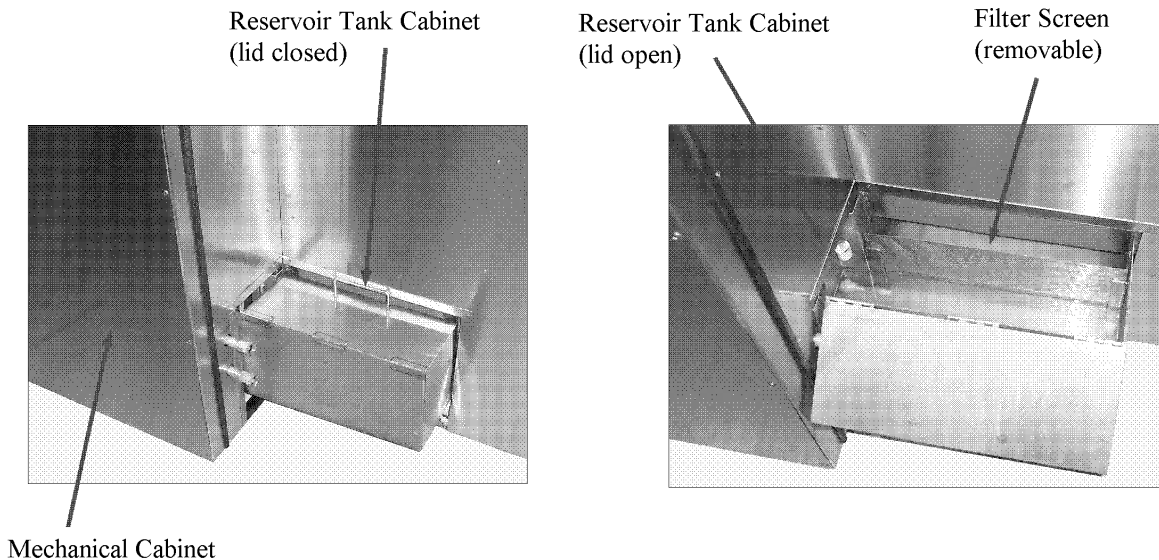

FILTER SCREEN

The Filter Screen is located inside the reservoir tank.

If the Filter Screen is clogged so that not enough water can get through to the wash chamber, the “LOW PRESSURE” light will blink to notify you to clean the filter.

If the Filter Screen becomes clogged and prevents water from getting to the pump, the machine will make a “growling” noise in addition to the “LOW PRESSURE” light blinking.

The Filter Screen is located inside the Reservoir Tank Cabinet next to the mechanical cabinet. With proper safety protection, reach into the reservoir, grab the screen, slide the screen back and lift out for cleaning. **REPLACE THE SCREEN IMMEDIATELY AFTER CLEANING.**

AQUA PHASE AQ-4000 Series Operating Manual

Control Panel Switches and Functions



Switch	Options/Function
“STOP” Button	When pressed, will stop all Aqua Phase wash functions
“START” Button	Must be pressed to start any Aqua Phase wash function
WASH TIME Selector Switch	Allows you to select the length of wash: “3 MIN” = Three minute wash cycle “5 MIN” = Five minute wash cycle “7 MIN” = Seven minute wash cycle
“RUN/DRAIN” Selector Switch	<p>“RUN”: Set to “RUN” to wash an item.</p> <p>“DRAIN”: Set to “DRAIN” to drain the water in the machine. The water should be drained when you are done washing for the day or if you relocate the machine. In order for the “DRAIN” function to work, the Wash Mode switch must be set to “CLEAN & DISINFECT” or “CLEAN ONLY”.</p>
WASH MODE Selector Switch	<p>“CLEAN & DISINFECT”: When this mode is selected, <i>Aqua Phase</i> will perform a complete wash and rinse for the time specified on the WASH TIME Selector Switch. It will then automatically apply disinfectant solution.</p> <p>“CLEAN ONLY”: When this mode is selected, <i>Aqua Phase</i> will perform a complete wash and rinse cycle for the length of time specified on the WASH TIME Selector Switch. It will not apply disinfectant.</p> <p>“DISINFECT ONLY”: When this mode is selected, <i>Aqua Phase</i> will apply disinfectant solution only. It will not wash or rinse.</p>

AQUA PHASE

AQ-4000 Series

Operating Manual

Important Operating Information

1. *Aqua Phase* will perform best with hot water temperatures between 125°F - 140° F.
 - Do not run water to the machine at temperatures greater than 150° F. When water temperatures are below 120° F, water spotting may occur.
2. If either the front or rear door of the machine is open, the unit will not operate.
3. If the front or rear door is opened in the middle of a wash cycle, the machine will stop.
 - After you close the door(s) and press the “**START**” button, *Aqua Phase* will start the wash cycle from the beginning.
4. The “**RUN/DRAIN**” switch needs be set to “**DRAIN**” only when you want to empty the machine of water.
 - Examples for drain use are:
 - a) You are done washing for the day.
 - b) You want to relocate the machine.
5. When the “**Low Pressure**” light blinks, the filter(s) screens need to be cleaned.
6. In order to drain the *Aqua Phase* when the Disinfectant Application System feature is installed, the selector switch (located on the control panel at the front of the machine) must be set on “**Clean Only**” or “**Clean & Disinfect**”.

Aqua Phase Basic Set-Up Procedures

If *Aqua Phase* has been transported during freezing weather, allow the machine to warm for 2-4 hours before running.

1. Read all *Aqua Phase* instructions and operations material.
2. Remove *Aqua Phase* from the pallet.
3. Move *Aqua Phase* to location of operation.
4. Remove items packed inside of the washer chamber for shipping (optional racks, trays, chemical solutions, and hoses will often be packed inside the wash chamber).
5. Connect the fill hose.
 - Hose connections on the machine are 5/8” national female hose. This size and type of hose connection is identical to garden hose connections
 - **DO NOT USE GARDEN HOSE.** Only use hose rated for 150° F or more for both the fill and drain hose.
6. Connect the drain hose.

Drain hose must be securely fastened to the drain. Pump discharge pressure may cause the hose to "whip".
7. After you are certain the fill and the drain connections are secure, slowly turn on your hot water supply.
8. Connect *Aqua Phase* to a standard 240 volt electrical service.
 - Press the reset button located on the GFCI (ground fault circuit interrupter).
 - **Do not** use a power extension cord between your wall outlet and *Aqua Phase*.

(continued on next page)

AQUA PHASE AQ-4000 Series Operating Manual

AQUA PHASE BASIC SET-UP PROCEDURES (Continued)

Warning:

Wear Protective Clothing When Working With Any Chemicals.

Warning:

Consult the material safety data sheets located in the back of this manual and your company's hazardous substance policy before handling any chemicals.

Key to *Aqua Phase* chemical solution hoses:

- The **RED** hose is for detergent.
 - The **BLUE** hose is for rinse-aid.
 - The **CLEAR** hose is for disinfectant, if installed.
9. Place the chemical solutions in the chemical tray (located inside the mechanical cabinet at the rear of the machine) at the locations marked "**DETERGENT**" and "**RINSE-AID**".
- Remove chemical bottle caps and place the appropriate colored hoses in bottle openings (**RED** hose for detergent/ **BLUE** hose for rinse-aid).
 - **Do not** dilute the Detergent or Rinse-Aid solutions.
10. If your unit has the Disinfectant Application System feature installed, place your bottle of disinfectant concentrate in the remaining space in the chemical tray (your unit may have a separate tray for the disinfectant solution).
- Insert the **CLEAR** hose into your bottle of disinfectant.
- NOTE:** The disinfection injection rate is preset at the factory for use of a disinfectant that requires a dilution rate of 1 oz. per gallon of water. Contact the factory if adjustment of the injection rate is necessary.
11. Set the "**RUN/DRAIN**" switch to "**RUN**". The "**RUN/DRAIN**" switch is located on the control panel at the front of the machine.
12. Close the front and the rear doors.
13. Ensure the *Aqua Phase* unit is level.
14. Press the "**START**" button. The "**START**" button is located on the control panel at the front of the machine.
- Allow *Aqua Phase* to run a complete cycle before washing anything.

If *Aqua Phase* does not start, see the "**TROUBLESHOOTING: Will not start**" section of this manual or call the factory for support.

AQUA PHASE AQ-4000 Series Operating Manual

Daily Operating Procedures

Recommended Start-up Procedures:

1. Inspect water supply hose connections - check to make certain fill and drain hoses are properly connected to *Aqua Phase*.
2. Reservoir Screen - check to make certain reservoir screen is clean and in place (reservoir screen is located in the water reservoir cabinet next to the mechanical cabinet outside the wash chamber).
3. Water Reservoir - check to make certain that the water reservoir is free of debris.
4. Rear Filter Screen (if present, newer models do not have a rear filter screen) - check rear filter screen and clean if necessary.
5. Chemical Solutions - check chemical supply levels.
6. Power Supply - plug in *Aqua Phase* and press the reset button located on the GFCI (ground fault circuit interrupter).
7. Water Supply - turn on water supply.

Recommended Shut-down procedures:

1. Drain *Aqua Phase*.
 - Set the "RUN/DRAIN" switch to "DRAIN". Press "START" button.
2. Water Supply - turn off water supply.
3. Power Supply - unplug *Aqua Phase*.
4. Reservoir Screen - clean reservoir screen (reservoir screen is located in the water reservoir cabinet next to the mechanical cabinet outside the wash chamber).
5. Water Reservoir - check to make certain that the water reservoir is free of debris.
6. Rear Filter Screen (if present, newer models do not have a rear filter screen) - check rear filter screen and clean if necessary.
7. Chemical Solutions - check chemical supply levels.

AQUA PHASE

AQ-4000 Series

Operating Manual

Aqua Phase Operating Procedures

1. **Load the item** to be washed into wash chamber and close the front door.
 - For *Aqua Phase* units equipped with the Conveyor Transfer System:
 - Place the entire item into the wash chamber.
 - Operate the conveyor "Forward/Reverse" switch on the control panel to move the item further into or out of the wash chamber for easy loading, positioning, and unloading.
2. **Select the "Wash Time"** (3, 5, or 7 minutes) on the control panel if your *Aqua Phase* is equipped with variable wash times. Choose the length of wash time based on the condition of the item to be washed.
3. **Set the "Run/Drain" switch** on the control panel to "Run".
4. **Select the wash mode** ("Clean & Disinfect", "Clean Only," or "Disinfect Only") on the control panel if your Aqua Phase is equipped with the Disinfectant Application System.
5. **Push the "START" button** on the control panel.

Aqua Phase Wash Sequence Description

1. After pressing the "START" button, the computer will check to see if there is water in the water reservoir. If the reservoir is not full of water, *Aqua Phase* will automatically fill to the appropriate level. The reservoir holds approximately 18 gallons.
2. When the reservoir is full, the pump will start and begin the wash cycle spraying the item being washed. Detergent is automatically injected shortly after the wash cycle begins.
3. The machine will now be in the wash phase and will continue for the wash time selected - 3, 5, or 7 minutes.
4. When the wash phase is complete, the dirty wash water will be pumped out of the machine to the drain.
5. *Aqua Phase* will automatically refill to the appropriate level with fresh water.
6. After the reservoir is filled with water, the pump will start and the machine will begin its final rinse phase. The rinse agent is automatically injected shortly after the rinse phase begins. The rinse cycle will last for approximately 45 seconds.
7. The disinfectant application cycle will begin if selected and if installed on your machine.
8. When all the lights are off, the wash sequence is complete.

During normal automatic operation, the rinse water remains in the machine and will be the wash water for the next item placed in the chamber. If you choose, you may drain the rinse water prior to beginning the next wash cycle. To drain the machine manually:

- Set the "RUN/DRAIN" switch to "DRAIN".
- Push the "START" button. The machine will drain the water.
- Prior to beginning the next wash cycle, set the "RUN/DRAIN" switch to "RUN".
- When the next wash cycle begins, the machine will automatically fill with fresh water for the wash phase.

AQUA PHASE AQ-4000 Series Operating Manual

Aqua Phase Adjustments & Maintenance

Unplug your Aqua Phase before doing any service to machine.

When you first receive your Aqua Phase machine:

1. If your unit has the Disinfectant Application System feature installed, adjust the disinfection injection rate if necessary.
 - **Note:** The disinfection injection rate is preset at the factory for use of a disinfectant that requires a dilution rate of 1 oz. per gallon of water. Contact the factory if adjustment of the injection rate is necessary.
 - See the “Disinfectant Application System Option” section of this manual for further information.

Weekly:

1. If present, check the rear filter screen(s) for rips and holes.
 - Rear filter screen(s) is located inside the filter bowl located in the mechanical cabinet at the rear of the machine. Newer models do not have a rear filter screen.
 - Replace damaged filters.
2. Check the spray nozzles & level sensors (located inside the wash chamber) for clogging.
 - Clean if necessary.
3. Check the power cord for any wear or damage.
 - If the power cord appears to be damaged in any way, do not operate the machine.
 - Replace the power cord prior to operating the machine.
4. Check to make certain that the water reservoir is free of debris.
 - Clean if necessary.

Monthly:

1. Test and reset the GFCI (ground fault circuit interrupter) in the *Aqua Phase* power cord.
2. Use de-liming agent to reduce scale build-up if needed. See “De-Liming Instructions” included with this manual.
3. Confirm that front and rear door safety switches are operating properly. If not, replace prior to using machine.

Semi-Annually or as Needed:

1. Adjust the tension of the conveyor transfer belt if necessary. Depending on your model and the features installed, you may or may not have a conveyor transfer system. Contact the factory if you have any questions.
2. Inspect front door gasket for wear or damage. Replace if necessary.

AQUA PHASE AQ-4000 Series Operating Manual

Disinfectant Application System (Optional Feature)

WARNING:

Follow all instructions provided by the manufacturer of the disinfectant solution that you choose to use including dwell time, application, removal, and proper handling of the disinfectant.

Your *Aqua Phase* machine may have the Disinfectant Application System feature installed. The Disinfectant Application System allows you to automatically apply a disinfectant solution. Your *Aqua Phase* machine is not, in and of itself, a disinfectant and the machine itself does not disinfect items washed in it. The disinfectant solution that you choose to use with the *Aqua Phase* Disinfectant Application System and the proper use of that disinfectant solution is responsible for the level of disinfection results that you achieve.

Disinfectant Solution:

- The **Disinfectant Application System** is preset at the factory to apply disinfectant at the rate of 1 ounces per gallon of water.
- Your *Aqua Phase* machine uses 100 to 110 ounces of water per disinfectant cycle.
- *Aqua Phase* does carry a variety of cleaning, rinse, and disinfectant solutions specifically formulated or chosen to work with your *Aqua Phase* machine. You may order your solutions by calling your dealer or *Aqua Phase* at 800-208-9274.

Disinfection Application System Operating Instructions:

1. Be sure that you are using a 1-ounce per gallon disinfectant. If not, see the notes below.
2. Place a one (1) gallon container of your disinfectant solution in the chemical tray (located inside the mechanical cabinet).
 - Your unit may have a separate tray for the disinfectant solution.
 - Insert the **CLEAR** hose into the disinfectant container.
 - Close the rear door.
3. At the Control Panel, select the desired WASH MODE (“Clean Only”, “Clean and Disinfect”, or “Disinfect Only”).

Notes:

The **Disinfectant Application System** is preset at the factory to apply disinfectant at the rate of 1 ounces per gallon of water.

If you choose to use a disinfectant that calls for a different dilution rate, *Aqua Phase* can be modified to accommodate that rate. For information on how to accomplish this modification, please call the factory for assistance and review the “Dema” technical information included with this manual.

AQUA PHASE AQ-4000 Series Operating Manual

Controller (PLC) Information

PLC= Programmable Logic Controller

Controls and Electronic Layout

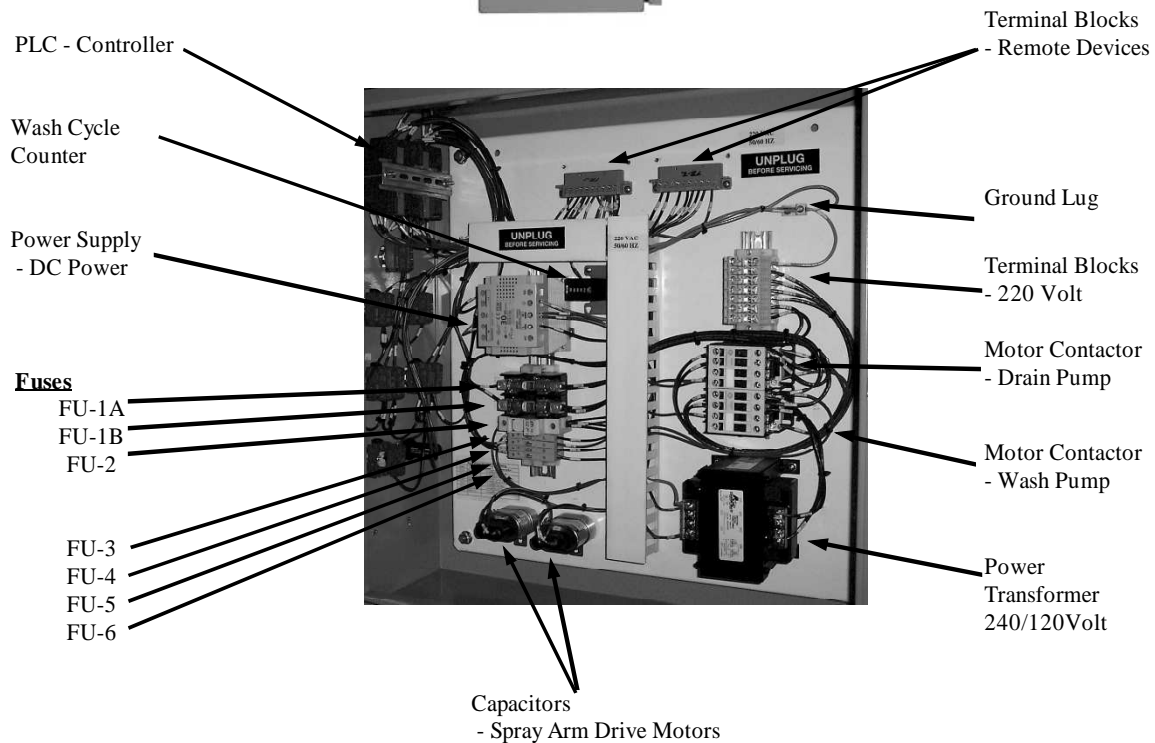
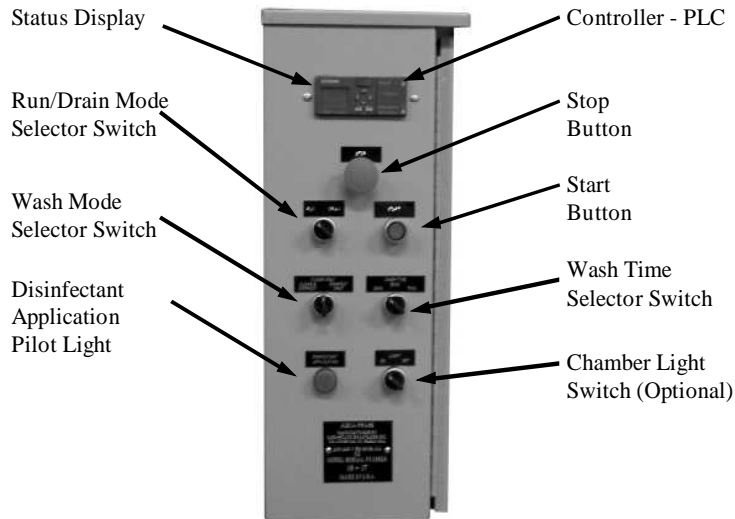

AQUA PHASE AQ-4000 Series Operating Manual

Controller (PLC) Information

Display Messages

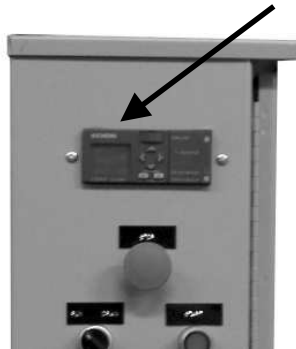

Message One

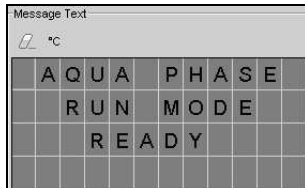

Run mode selected.

- Doors closed.
- Read to start.

Message Two

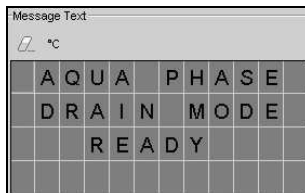

Drain mode selected.

- Doors closed.
- Read to start.

Message Three

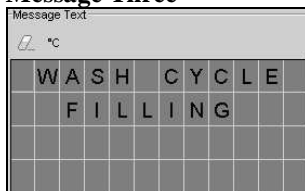

Machine is filling for wash cycle.

- Run mode selected.
- Doors closed.
- "Start" button pushed.

Message Four

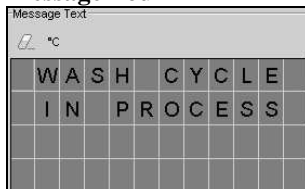

Machine is in wash cycle.

- Machine done filling for wash cycle.
- Detergent solution automatically injected.
- Wash cycle will be for length of time selected (3,5, or 7 min)

AQUA PHASE AQ-4000 Series Operating Manual

Controller (PLC) Information

Display Messages (continued)

Message Five

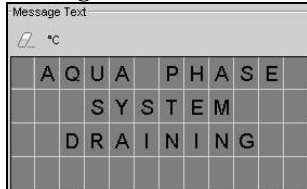

1. Machine is done with wash cycle.
 - Wash water is being drained.
- Or
2. Drain mode selected and "Start" button pushed.

Message Six

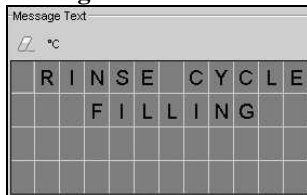

- Machine is beginning rinse cycle.
- Wash cycle completed.
 - Wash water drained.
 - Machine is filling with fresh water for rinse cycle.

Message Seven

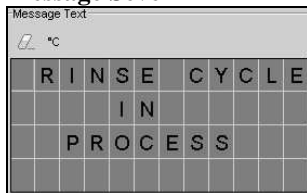

- Machine is in rinse cycle.
- Machine done filling for rinse cycle.
 - Rinse solution automatically injected.
 - Rinse cycle will be for approximately 1 minute.

Message Eight

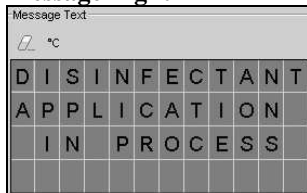

- Disinfectant Application System is running.
- Fresh water being mixed with disinfectant solution.
 - Item in wash chamber being sprayed with solution.
1. "Clean and Disinect" selected before wash cycle started.
 - Wash and rinse cycle done.
- Or
2. "Disinfect Only" selected and "Start" button pushed.

Message Nine

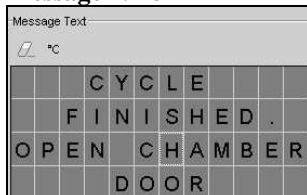

- Machine has completed selected operation.
- Front door to Wash Chamber must be opened before next operation can begin.
- Item removed/loaded.
- Wash chamber inspected for debris.
- Safety switches operational.

AQUA PHASE AQ-4000 Series Operating Manual

Fuses

The critical electrical devices on *Aqua Phase* are protected by fuses from electrical anomalies. Without a properly fused electrical system, there would be risks to the operator and to the critical (expensive) electrical devices.

If you suspect a fuse may be blown, unplug the machine before investigating.

Typically, seven fuses are located on *Aqua Phase* (depending on optional features, there may be additional fuses located in the control panel):

Name	Fuse Type	Purpose	Location
FU-1A	RKF 20A (FRN-R-20)	Pump Motors & Main Fuse - 240v	Control Panel
FU-1B	RKF 20A (FRN-R-20)	Pump Motors & Main Fuse - 240v	Control Panel
FU-2	CC 5A (FNQ-R-5)	Electronic System - 110v	Control Panel
FU-3	GMD 1.5A (GMD-1.5A)	PLC Outputs - 110v	Control Panel
FU-4	GMD 1.5A (GMD-1.5A)	Spray Arm Drive Motors - 110v	Control Panel
FU-5	GMD 1.5A (GMD-1.5A)	PLC Inputs - DC 24v	Control Panel
FU-6	GMD 1.5A (GMD-1.5A)	Control Switches - DC 24v	Control Panel
FU-7 (optional)	GDC-5A (GDC-5A)	Conveyor Motor - 110v	Control Panel
GFCI	GFCI	Ground Fault Protector	Power Cord

Effects of a blown fuse(s):

Name	Status	Condition
FU-1A	If Blown	System will be dead. No power to any devices. No status lights on PLC.
FU-1B	If Blown	System will be dead. No power to any devices. No status lights on PLC.
FU-2	If Blown	System will be dead. Power to chemical primer switch. No status lights on PLC.
FU-3	If Blown	No activity from pressing “ START ” button. C will not be on.
FU-4	If Blown	System will pump, but no sweeping spray action will be heard.
FU-5	If Blown	No activity from pressing “ START ” button.
FU-6	If Blown	No activity from pressing “ START ” button.
FU-7	If Blown	System will operate, but conveyor transfer system will not function.
GFCI	If Tripped	System will be dead. No power to any devices. No status lights on PLC. Facility power supply to machine must be on to reset GFCI.

Fuses listed above with the exception of the “GFCI” are located inside the control panel cabinet.

AQUA PHASE
AQ-4000 Series
Operating Manual

Troubleshooting Guide

This Guide may help you isolate a problem and as a result, eliminate the need to contact technical support, allowing continued productivity. Prior to attempting any suggested servicing procedures, **unplug Aqua Phase** from the power source.

Contents

<u>Description</u>	<u>Page</u>
Troubleshooting:	
Will Not Start	2
Will Not Fill With Water	3
Will Not Stop Draining	4
Will Not Stop Filling	5
Water Spots Or Cloudy Film On Items Washed	6
Items Not Cleaned Properly	7
“Growling” Noises	8
Water Sprays While In “DRAIN” Mode	9
Using Too Much Solution	9
Low Pressure Indicator Light Always On	10
Hard Water Build-Up	10

For additional information, consult your machine's operating manual or contact Aqua Phase.

AQUA PHASE

AQ-4000 Series

Operating Manual

Problem: ***Aqua Phase* will not start.**

Possible Causes/Solutions:

- 1) Unit not plugged-in.
 - Connect ***Aqua Phase*** to a standard 20 AMP electrical service.
 - Press the reset button located on the GFCI (ground fault circuit interrupter) in the ***Aqua Phase*** power cord. The power cord must be plugged into a working outlet in order to reset the GFCI.
 - For added safety, it is **recommended** to use a ground fault receptacle at the power source where the machine will be plugged in.
- 2) GFCI in the ***Aqua Phase*** power cord not reset.
 - Press the reset button located on the GFCI in the ***Aqua Phase*** power cord.
- 3) Rear door open.
 - Check that the rear door is properly closed.
- 4) Front door open.
 - Check that the front door is properly closed.
- 5) Power supply circuit breaker tripped.
 - Have a qualified individual check that the circuit breaker of the electrical circuit to the machine is operating properly.
 - The circuit breaker should be a 20-amp unit.
- 6) Defective front or rear door safety switch.
 - **Unplug** the machine from the power supply.
 - Call the factory for support.
- 7) Defective GFCI (ground fault circuit interrupter).
 - **Unplug** the machine from the power supply.
 - Call the factory for support.
- 8) Blown fuse in the control assembly.
 - **Unplug** the machine from the power supply.
 - Remove the control panel cover.
 - Remove the four fasteners located on the left and right of the control panel cover.
 - Remove only the top two screws from front control panel face.
 - If present, remove the top two screws from the rear of the control panel cover.
 - Have an OHM meter available and check the fuses.
 - See “**Fuses**” section of your machine's operating manual for the fuse numbers to check.
 - Call the factory for service assistance.
- 9) Defective "START" switch.
 - **Unplug** the machine from the power supply.
 - Call the factory for support.
- 10) Power outage to building.
 - Report outage as appropriate.

AQUA PHASE

AQ-4000 Series

Operating Manual

Problem: ***Aqua Phase* will not fill with water.**

Possible Causes/Solutions:

- 1) No power to the machine.
 - Connect ***Aqua Phase*** to a standard 20 AMP electrical service.
 - Press the reset button located on the GFCI in the ***Aqua Phase*** power cord.
- 2) Water supply is not turned on.
 - After you are certain the fill and the drain connections are secure, slowly turn-on your water supply.
- 3) Kink in water supply hose.
 - Inspect water supply hose to ensure no sharp bends in hose.
- 4) Water supply pressure is too low.
 - Turn-off water supply.
 - Disconnect water supply hose from ***Aqua Phase***.
 - Position end of hose over drain, slowly turn-on your water supply. Note if rate of water flow appears adequate. If adequate water flow, turn-off water supply, reconnect hose to ***Aqua Phase***, turn-on water supply.
- 5) Fill valve solenoid is damaged or has debris stuck inside it.
 - See “**Valve Inspection Procedures**” located in the ***Servicing Procedures Guide*** section of your machine's operating manual.
 - Remove the fill hose from the "FILL" line connection at the machine. Check to ensure that the filter screen/washer is in place and intact. If problem remains, call the factory.
- 6) Filter screen/washer located inside "FILL" line connection of ***Aqua Phase*** is plugged.
 - Turn-off water supply. Disconnect water supply hose from ***Aqua Phase***.
 - Inspect condition of Filter screen/washer. If plugged, contact ***Aqua Phase*** for replacement. You may temporarily replace Filter screen/washer with a standard hose washer; however, long-term operation without the Filter screen/washer may cause damage to the Fill valve solenoid.
- 7) Defective high-level water control probe.
 - **Unplug** the machine from the power supply.
 - Call the factory.

AQUA PHASE

AQ-4000 Series

Operating Manual

Problem: ***Aqua Phase will not stop draining/ draining takes too long.***

Possible Causes/Solutions:

- 1) Foam in water reservoir area – caused by something on the item washed or use of a foaming detergent or rinse-aid. Foam may affect certain sensors that control the filling and draining of water.
 - Press the “**STOP**” button and wait a few minutes until the foam dissipates.
 - Remove hose from all cleaning supply bottles in the rear of the machine.
 - Press the “**START**” button and allow *Aqua Phase* to do a complete cycle.
 - Repeat the preceding steps until *Aqua Phase* starts draining normally.
- 2) Filter Screen(s) not clean.
 - Clean rear filter screen if installed - (rear filter screen is located inside the filter bowl(s) located in the mechanical cabinet at the rear of the machine).
 - Clean reservoir screen (reservoir screen is located in the bottom of the water reservoir located inside the wash chamber).
- 3) Excess build-up of hard water deposits on low-level probe.
 - **Unplug** the machine from the power supply.
 - Locate the low-level probe in the water reservoir inside the wash chamber. Depending on your model, the low-level probe may be inside a protective chamber in the reservoir.
 - For models with metal "rod style" low-level probe -
 - Run an emery board or fine grade of sandpaper over and around the end of the low-level probe.
 - For models with plastic "float style" low-level probe -
 - Inspect probe to ensure that it is clear of debris and moves freely.
- 4) Damaged or defective low-level probe.
 - **Unplug** the machine from the power supply.
 - Inspect the low-level probe for damage, such as a cracked fitting or binding.
 - Replace if damaged – you may order replacement parts by calling your dealer or the factory.
- 5) Level control sensor set too high.
 - Call the factory for assistance.
- 6) Defective level sensor module.
 - **Unplug** the machine from the power supply.
 - Call the factory for assistance.
- 7) Kink in water drain hose.
 - Inspect water drain hose to ensure no sharp bends in hose.
- 8) If installed, Drain pump impeller clogged with debris.
 - Depending on your model, your machine may have a separate pump for draining.
 - See “**Pump Impeller Inspection Procedures**” located in the *Servicing Procedures Guide* section of your operating manual. It is recommended that you contact the factory before attempting to clear debris from the drain pump impeller.

AQUA PHASE

AQ-4000 Series

Operating Manual

Problem: ***Aqua Phase* will not stop filling/water coming out of the front door.**

Immediately:

- Press the “**STOP**” button.
- Shut off the water supply.

Possible Causes/Solutions:

- 1) Front door gasket damaged or worn.
 - Inspect front door gasket for wear or damage.
 - Replace if necessary – you may order replacement parts by calling your dealer or the factory.
- 2) Fill valve has debris stuck in it.
 - See “**Valve Inspection Procedures**” located in the *Servicing Procedures Guide* section of your machine's operating manual.
 - Remove the fill hose from the fill line connection at the machine. Check to ensure that the filter screen/washer is in place and intact.
 - If problem remains, call the factory for assistance.
- 3) Excess build-up of hard water deposits on high-level probe.
 - **Unplug** the machine from the power supply.
 - Locate the high-level probe in the water reservoir inside the wash chamber. Depending on your model, the high-level probe may be inside a protective chamber in the reservoir.
 - For models with metal "rod style" high-level probe -
 - Run an emery board or fine grade of sandpaper over and around the end of the low-level probe.
 - For models with plastic "float style" high-level probe -
 - Inspect probe to ensure that it is free of debris and moves freely.
- 4) Damaged or defective high-level probe.
 - **Unplug** the machine from the power supply.
 - Inspect the high-level probe for damage, such as a cracked fitting or binding.
 - Replace if damaged – you may order replacement parts by calling your dealer or the factory.
- 5) Level control sensor set too high.
 - Call the factory for assistance.
- 6) Defective level sensor module.
 - **Unplug** the machine from the power supply.
 - Call the factory for assistance.

AQUA PHASE

AQ-4000 Series

Operating Manual

Problem: **Items washed have water spots or cloudy film.**

Possible Causes/Solutions:

Undiluted AQ-260 Rinse-aid solution requires a water temperature at or above 130°F to properly activate.

- 1) Water temperature below 130°F.
 - Check the temperature of the water reaching the machine.
 - Drain the machine.
 - Press the “**START**” button. Allow the machine to fill.
 - As soon as *Aqua Phase* begins to pump, press the “**STOP**” button.
 - Open the front door, place a thermometer in the water reservoir to check the water temperature. Water temperature should be at or close to 130°F. **Note:** It is very common for hot water heater temperature dial indicators to be inaccurate.
- 2) Rinse-aid solution container is empty.
 - Check the level of rinse-aid solution, refill if necessary. The chemical solutions are located inside the mechanical cabinet at the rear of the machine.
- 3) Rinse chemical injector hose or fittings cracked or loose.
 - Inspect chemical hoses for cracks and inspect chemical hose fittings for cracks or if loose.
 - Replace if damaged – you may order replacement parts by calling your dealer or the factory.
- 4) Dilution of rinse-aid solution required.
 - Dilute the rinse-aid by 10% with water and see if water spotting persists. Continue to dilute the rinse-aid up to 50% with water in order to correct this problem.

Notes:

The rinse-aid injection rate is preset at the factory for the worst possible water condition expected to be found.

If spotting or clouding is present only on the first item washed, it is possible that you will need to run a “warm-up cycle” with *Aqua Phase*. Run a “three-minute” wash cycle with the wash chamber empty to allow the chamber to be warmed-up prior to commencing normal washing operations.

If problem persists, call the factory for assistance.

AQUA PHASE

AQ-4000 Series

Operating Manual

Problem: **Items not cleaned properly.**

Possible Causes/Solutions:

- 1) Detergent solution container is empty.
 - Check the level of detergent, refill if necessary. The chemical solutions are located inside the mechanical cabinet at the rear of the machine.
- 2) Filter Screen(s) not clean.
 - Clean rear filter screen if installed - (rear filter screen is located inside the filter bowl(s) located in the mechanical cabinet at the rear of the machine).
 - Clean reservoir screen (reservoir screen is located in the bottom of the water reservoir located inside the wash chamber).
- 3) Detergent and rinse chemical injector hose or fittings cracked or loose.
 - Inspect chemical hoses for cracks and inspect chemical hose fittings for cracks or if loose.
 - Replace if damaged – you may order replacement parts by calling your dealer or the factory.
- 4) Spray nozzles clogged.
 - Visually inspect spray nozzles for debris.
 - For spray nozzles that are clogged, note the position of the spray nozzle's relative spray angle.
 - Remove, clean, and replace the nozzles in their original locations at their original spray angles.
- 5) Longer wash cycle required.
 - Set the wash cycle time to "**7 minutes**" or to the longest time cycle available.
 - Press the "**START**" button, and allow *Aqua Phase* to run a complete cycle.
- 6) Water temperature too low.
 - Check the temperature of the water reaching the machine.
 - Drain the machine.
 - Press the "**START**" button. Allow the machine to fill.
 - As soon as *Aqua Phase* begins to pump, press the "**STOP**" button.
 - Open the front door, place a thermometer in the water reservoir to check the water temperature. The recommend water temperature is 130 – 140 °F.

Note:

If your machine is equipped with a "**Low Pressure**" indicator light located on the control panel of the machine and the light does not come on when the filters are extremely dirty, the low-pressure sensor may be defective. Call the factory for support.

AQUA PHASE

AQ-4000 Series

Operating Manual

Problem: ***Aqua Phase* makes “growling” noise and/or the volume of spray inside the chamber is low.**

The “growling” noise is caused by air getting into the pump impeller. Growling noise is normally heard at the end of the drain cycle. If you hear it continually, you have one of the following problems.

Possible Causes/Solutions:

- 1) Machine not in level operating position.
 - Ensure that the *Aqua Phase* unit is level.
- 2) Foam in water reservoir area – caused by something on the item washed or use of a foaming detergent or rinse-aid. Foam may affect certain sensors that control the filling and draining of water.
 - Press the “**STOP**” button and wait a few minutes until the foam dissipates.
 - Remove hose from all cleaning supply bottles in the rear of the machine.
 - Press the “**START**” button and allow *Aqua Phase* to do a complete cycle.
 - Repeat the preceding steps until *Aqua Phase* starts draining normally.
- 3) Reservoir filter screen not clean.
 - Clean reservoir screen (reservoir screen is located in the bottom of the water reservoir located inside the wash chamber).
- 4) High-level probe covered with debris.
 - **Unplug** the machine from the power supply.
 - Locate the high-level probe in the water reservoir inside the wash chamber. Inspect for debris covering the probe, remove debris if present.
- 5) Chemical injector hose or fittings cracked or loose.
 - Inspect chemical hoses for cracks and inspect chemical hose fittings for cracks or if loose.
 - Replace if damaged – you may order replacement parts by calling your dealer or the factory.
- 6) Chemical pump hose cracked.
 - Inspect hoses located inside the chemical pumps for cracks.
 - Replace if damaged – you may order replacement parts by calling your dealer or the factory.
- 7) If present on your machine, Drain valve has debris stuck in it - allowing water to run out the drain line.
 - **Unplug** the machine from the power supply.
 - See “**Valve Inspection Procedures**” located in the *Servicing Procedures Guide* section of your machine's operating manual.
- 8) Pump impeller clogged with debris.
 - See “**Pump Impeller Inspection Procedures**” located in the *Servicing Procedures Guide* section of your machine's operating manual. It is recommended that you contact the factory before attempting to clear debris from the pump impeller.
- 9) Level control sensor set too high.
 - Call the factory for assistance.

AQUA PHASE AQ-4000 Series Operating Manual

Problem: **Water sprays inside chamber while machine is in “DRAIN” mode.**

Possible Causes/Solutions:

- 1) Main chamber solenoid valve is stuck open. Typically, this is due to the filter(s) not being properly reinstalled after cleaning allowing debris to flow through the valve.
 - **Unplug** the machine from the power supply.
 - See “**Valve Inspection Procedures**” located in the *Servicing Procedures Guide* section of your machine's operating manual.
 - If problem remains, call the factory for assistance.

Problem: ***Aqua Phase* seems to be using too much detergent or rinse solution.**

Possible Causes/Solutions:

- 1) Chemical pump hose cracked.
 - Inspect hoses located inside the chemical pumps for cracks.
 - Replace if damaged – you may order replacement parts by calling your dealer or the factory.
- 2) Chemical pump roller assembly is worn, resulting in the chemical pump hose not being completely pinched.
 - Inspect chemical pump hose roller and determine if chemical pump hose is being fully pinched. If not, replace both the chemical hose and the roller assembly.

AQUA PHASE AQ-4000 Series Operating Manual

Problem: ***Aqua Phase* "Low Pressure" indicator light - if installed
 - is always on.**

Possible Causes/Solutions:

The "Low Pressure" indicator light is to inform you that your machine may not be spraying an adequate amount of water to achieve proper cleaning.

- 1) Filter screens not clean.
 - Clean rear filter screen(s) if installed - (rear filter screen is located inside the filter bowl(s) located in the mechanical cabinet at the rear of the machine).
 - Clean reservoir screen (reservoir screen is located in the bottom of the water reservoir located inside the wash chamber).
- 2) Chemical valve injector hose or fittings cracked.
 - Replace – you may order replacement parts by calling your dealer or the factory.
- 3) Defective pressure sensor.
 - Replace – you may order replacement parts by calling your dealer or the factory.
- 4) Pump impeller clogged with debris.
 - See “**Pump Impeller Inspection Procedures**” located in the *Servicing Procedures Guide* section of your machine's operating manual. It is recommended that you contact the factory before servicing the pump impeller.

Problem: ***Aqua Phase* has hard water build-up and scale on walls.**

As with any cleaning operation utilizing water, it is recommended that soft water be used.

Hard water contains a relatively high level of lime, calcium and iron. Hard water will affect cleaning performance the same as it does your home laundry. After an extended period of time, the inside stainless steel walls of *Aqua Phase* will accumulate a white deposit. If you are experiencing this condition, see the “**De-Liming Instructions**” section of your machine's operating manual.

AQUA PHASE AQ-4000 Series Operating Manual

SERVICING PROCEDURES GUIDE

Warning: Unplug the machine from the power supply before performing any service procedures.

Pump Impeller Inspection Procedures

It is recommended that you contact the factory at 800-208-9274 before attempting to clear debris from the pump impeller. Removing debris from the pump impeller requires disassembly of the pump.

1. **Unplug** the machine from the power supply.
2. Disconnect the electrical wires at the pump.
3. Disconnect the hose going to the inlet of the pump.
4. Disconnect the hose or piping from the pump outlet.
5. Remove the pump mounting bolts from the underside of the machine.
6. The pump is composed of two components: the pump head and the pump motor.
 - You do not need to remove the pump head from the pump motor.
 - You do need to take the pump head apart.
7. Remove the bolts holding the pump head together.
8. You may need to tap (hit) the pump head assembly to free the two halves.
9. Inspect the pump impeller.
 - Check the impeller housing and the inlet elbow for any obstructions, and remove debris if necessary.
10. Inspect the pump seal/gasket. Replace if damaged.
 - If your pump has an "O-Ring" seal, you may order a replacement from the factory.
 - If your pump has a gasket type seal, replace the seal using TRV™ water type gasket seal material.
11. Reassemble and reinstall the pump.

Valve Inspection Procedures

These valve inspection procedures can be done while the valve is still piped in. See the technical data sheet related to valves included with your operations manual. The technical data sheets provides assembly details.

- The **FILL** valve is located shortly after the Fill hose connection.
 - If installed, the **DRAIN** valve is located shortly before the Drain hose connection.
 - If installed, the **MAIN CHAMBER** valve is piped in-line after the pump outlet.
1. **Unplug** the machine from the power supply. Shut off the water supply.
 2. Remove the solenoid valve coil retaining cap/washer.
 3. Remove the solenoid electrical coil.
 4. Remove the four bolts from the solenoid top.
 5. Carefully, pull the solenoid top away from the solenoid body.
 6. Check for debris.
 7. Remove the rubber valve diaphragm. Inspect the diaphragm for damage (e.g., cracking, blistering). Replace if damaged.
 8. Check for debris on the valve seat and remove debris if present. Ensure the valve piston is free-moving.
 9. Reassemble the valve. Be certain to tighten the four bolts in an alternating manner.
 10. If problem remains, contact the factory.

AQUA PHASE AQ-4000 Series Operating Manual

Aqua Phase De-Liming Instructions

Introduction:

Read all instructions before proceeding. The following detailed instructions are for “de-liming” your machine if it becomes necessary.

Call the factory with any questions regarding these instructions. For your convenience, **AQ-725 De-liming Solution** may be ordered directly from *Aqua Phase* by calling 800-208-9274.

As with any cleaning operation using water, it is recommended that soft water be used.

Hard water contains a relatively high level of lime, calcium and iron. Hard water will affect cleaning performance the same as it does your home laundry. After an extended period of time, the inside stainless steel walls of *Aqua Phase* will accumulate a white deposit.

If this build-up is extensive, we recommend the use of a “de-liming” solution. A de-liming solution purchased from a local hardware store such as “CLR” will help, but it is not generally as effective as an industrial type de-liming agent.

We have specially formulated the **AQ-725 De-liming Solution** to be used weekly, or as needed, to keep your *Aqua Phase* free from mineral build-up. The easy, ready-to-use quart bottles are pre-measured for the proper dilution rate for a single application. Packaged with 12 quarts per case, a routine schedule for de-liming your *Aqua Phase* can be easily maintained.

Warning:

WEAR PROTECTIVE CLOTHING WHEN WORKING WITH ANY CHEMICALS.

Consult the material safety data sheets and your company’s hazardous substance policy before handling any chemicals.

DANGER: Causes eye and skin burns. Harmful if swallowed. Contains Hydroxyacetic and Phosphoric Acids.

FIRST AID: In case of eye contact, immediately flush with running water for at least 15 minutes and obtain medical aid. For skin contact, flush with running water. If swallowed, do not induce vomiting. Drink large amounts of water and call a physician immediately.

**KEEP OUT OF REACH OF CHILDREN
MIX ONLY WITH WATER - DO NOT USE ON ALUMINUM
FOR INDUSTRIAL USE ONLY**

*** Continued on next page ***

AQUA PHASE

AQ-4000 Series

Operating Manual

De-Liming Procedures:

Do not climb into the Wash Chamber unless you have factory authorization.

1. Carefully read and follow the notices and instruction labels of the de-liming solution you will be using.
2. Drain *Aqua Phase*.
3. Remove the Rinse and Detergent hoses from the cleaning solution bottles inside the mechanical cabinet at the rear of the machine.
4. Set the Run/Drain switch to “**RUN**”.
5. Set the mode switch to “**CLEAN**”.
6. Set the wash cycle time to “**7 minutes**” or the longest time cycle available.
7. Press the “**START**” button and allow *Aqua Phase* to fill.
8. As soon as *Aqua Phase* starts to spray water, press the “**STOP**” button.
 - At this point, the *Aqua Phase* water reservoir will be full. The *Aqua Phase* reservoir holds 5.5 gallons of water.
9. Open the front door and pour the proper amount of de-liming solution directly into the water that is in the reservoir of the machine.
 - **BE CERTAIN** to add the proper amount of de-liming solution according to the dilution rate recommended by the manufacturer of the de-liming solution concentrate you are using (the *Aqua Phase* reservoir holds 5.5 gallons of water).
10. Close the front door and press the “**START**” button.
 - *Allow Aqua Phase to run for no longer than 4 minutes.*
 - Press the “**STOP**” button.
11. Wait approximately 5 minutes.
 - Set the wash cycle time to “**7 minutes**” or to the longest time cycle available.
 - Press the “**START**” button, and allow *Aqua Phase* to run a complete cycle.
12. Clean the rear filter if present (located in the mechanical cabinet).
 - If the rear filter is not seated properly in the filter bowl, you can expect most of the spray nozzles inside the wash chamber to become clogged.

*** Continued on next page ***

AQUA PHASE

AQ-4000 Series

Operating Manual

De-Liming Procedures (continued):

13. Press the “**START**” button and allow *Aqua Phase* to run another complete cycle.
14. Examine and clean the front reservoir chamber filter and the rear filter.
 - Repeat steps 10 – 13 until the filter(s) collect minimal debris.
 - You may select “**3 minutes**” or the shortest time cycle available when repeating Steps 10 – 13.
15. Examine and clean the reservoir filter located inside the wash chamber reservoir.
16. Drain *Aqua Phase*.
17. Disconnect *Aqua Phase* from power source.
18. Shut-off the water supply to *Aqua Phase*.

Other Items:

Aqua Phase may not stop draining during Step 11 above. The de-liming solution will normally create foam inside the wash chamber. The foam may affect certain sensors that control the filling and draining of water.

In Step 11 above, if *Aqua Phase* does not stop draining after a few minutes, perform the following:

- a) Press the “**STOP**” button and wait a few minutes until the foam dissipates.
- b) Press the “**START**” button and allow *Aqua Phase* to do a complete cycle.
- c) Repeat the preceding Steps a) and b) until *Aqua Phase* starts draining normally.
- d) Return to Step 11 above.

Check for debris in the Spray Nozzles. If your unit has a rear filter and the rear filter is not seated properly in the filter bowl at all times, you can expect most of the spray nozzles to become clogged during the de-liming of your machine. After you have completed the de-liming procedures above, check the spray nozzles to make certain they are not clogged.

**AQUA PHASE
AQ-4000 Series
Operating Manual**

**AQUA PHASE 4000
LIMITED WARRANTY**

Aqua Phase washers are warranted by Mid-State Stainless, Inc. (MSSI) to the original user against defects and workmanship or material under normal use:

- (a) for one year on any pumps, motors, valves, and pressure switches; and
- (b) for one year on automatic controls and control components.
- (c) for five years on the stainless steel wash chamber, pro-rated at 20% per year.
- (d) 90-days on labor for any of the above.

This limited warranty ensues on the day of purchase.

This warranty is valid only if Aqua Phase AQ-240 detergent and AQ-260 rinse-aid are used in the Aqua Phase washer. The use of cleaning and rinse agents other than those listed above without express written consent from Aqua Phase/Mid-State Stainless, Inc. shall void this warranty immediately.

If the Buyer notifies Mid-State of a warranty claim during the appropriate warranty period and the Buyer affords Mid-State a reasonable opportunity to inspect the product, and if the product is in fact found to be defective by reason of latent or inherent defect in material or workmanship and returned to an authorized service location, as Mid-State designates, shipping costs prepaid, then Mid-State will, at Mid-State's election, either repair such product or replace the product F.O.B. Factory. No product shall be returned without Mid-State's prior consent in writing.

Limitation of Liability: Disclaimer of Implied Warranties. The Buyer's sole and exclusive remedy on account of the furnishing of products or services by Mid-State shall be to secure the repair or replacement of the defective products from Mid-State on the terms and subject to the conditions specified above. Mid-State shall have no responsibility for any failure of the products or of related equipment or any loss, damage or injury resulting from: (a) the improper design, manufacture, maintenance or operation of any equipment into which the products are incorporated or in connection with which the products are used; or (b) the use of the products for other than their intended purpose; or use or operation outside the specified environmental conditions; or (c) the failure of the Buyer or any other party to maintain the products properly; or (d) any failure resulting from causes external to the products after delivery; or (e) any failure resulting from modifications to the products other than modifications made by Mid-State. Mid-State shall not in any event be liable for any costs incurred by Buyer, including, without limitation, the cost of any labor expended on any product.

MID-STATE MAKES NO WARRANTIES, OTHER THAN THE LIMITED WARRANTY SPECIFIED ABOVE, OR REPRESENTATIONS, EXPRESS OR IMPLIED, WITH RESPECT TO THE PRODUCT OR ANY SERVICE, ADVICE, OR CONSULTATION, IF ANY, FURNISHED TO THE BUYER OR ANY OTHER PARTY BY MID-STATE OR ITS REPRESENTATIVE. MID-STATE SPECIFICALLY DISCLAIMS THE IMPLIED WARRANTIES OF MERCHANTABILITY AND FITNESS FOR A PARTICULAR PURPOSE. THE REMEDIES SET FORTH ABOVE ARE THE ONLY REMEDIES AVAILABLE TO ANY PERSON FOR BREACH OF ANY COVENANT, DUTY OR OBLIGATION ON THE PART OF MID-STATE HEREUNDER. MID-STATE SHALL NOT BE LIABLE FOR ANY LOSS, PERSONAL INJURY OR PROPERTY DAMAGE DIRECTLY OR INDIRECTLY ARISING FROM THE USE OF SUCH PRODUCT, ADVICE OR SERVICE, OR FOR INCIDENTAL, CONSEQUENTIAL OR PUNITIVE DAMAGES OF ANY DESCRIPTION, WHETHER ANY SUCH CLAIM BE BASED UPON WARRANTY, CONTRACT, NEGLIGENCE, STRICT LIABILITY OR OTHER TORT, OR OTHERWISE.

CUSTOMER SUPPLIED
230 VAC SINGLE PHASE
25 AMP

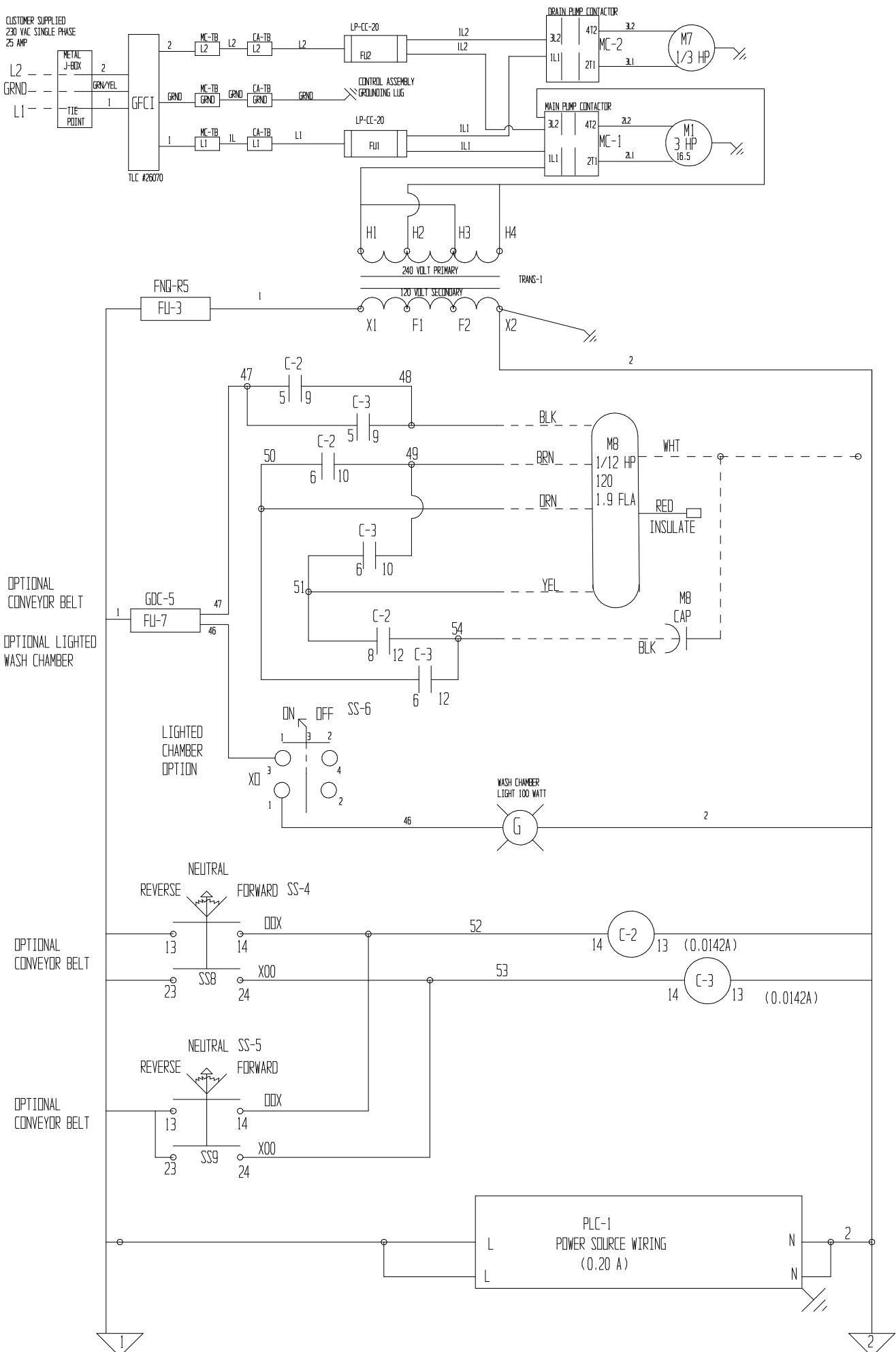

OPTIONAL
CONVEYOR BELT
OPTIONAL LIGHTED
WASH CHAMBER

OPTIONAL
CONVEYOR BELT

OPTIONAL
CONVEYOR BELT

REVERSE NEUTRAL FORWARD SS-4

REVERSE NEUTRAL SS-5 FORWARD

PLC-1
POWER SOURCE WIRING
(0.20 A)



Model	Aqua Phase with Disinfectant App Sys	Software	Cadkey 97	Controller	LOGO 12/24RC & DMB 24R	
Date	MARCH 8 2005	Directory	3000			
Page	2 of 3	Levels	110			
File	AQ-3000 MASTER					

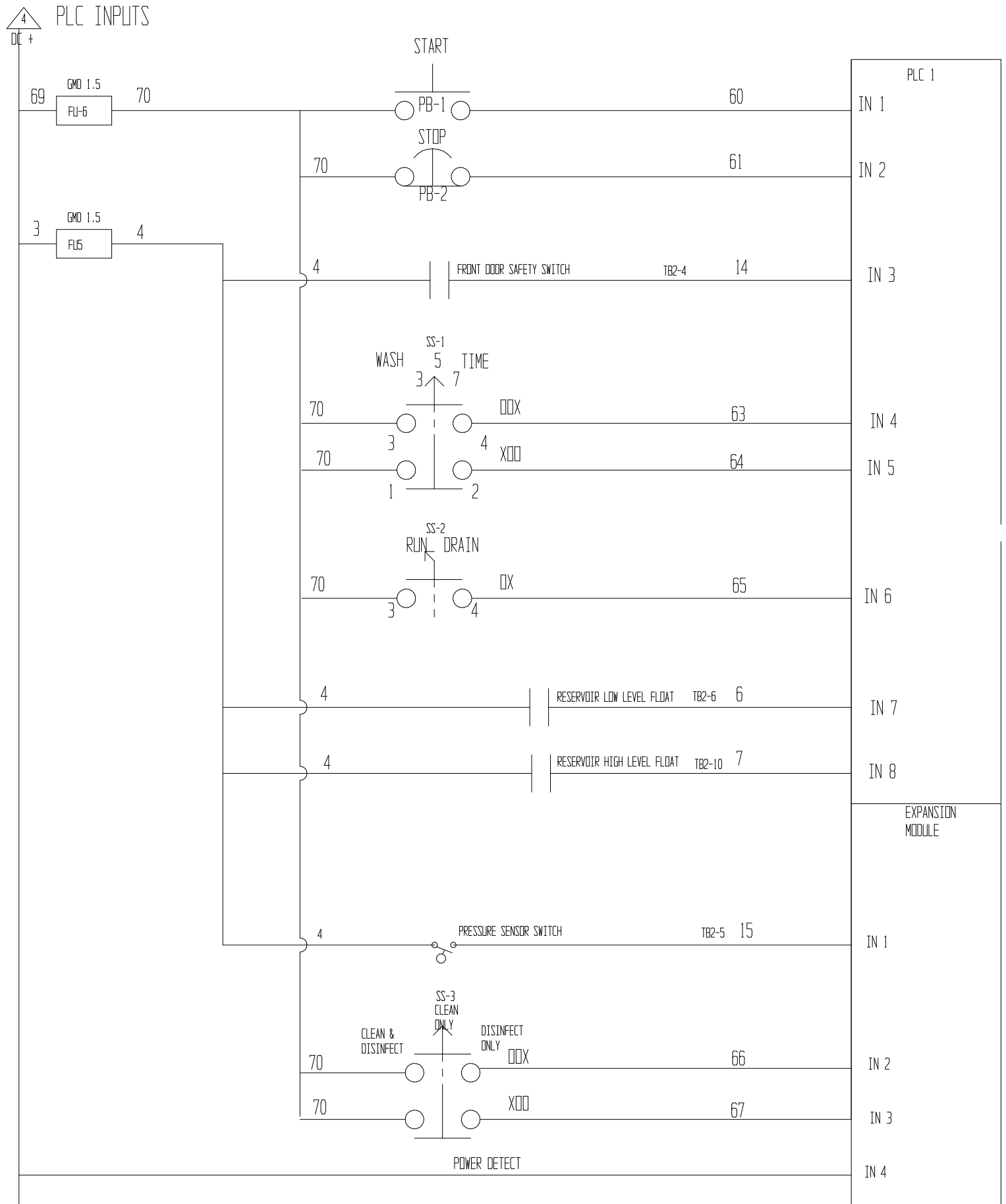

Model	Aqua Phase with Disinfectant App Sys	Software	Cadkey 97	Controller	LOGO 12/24RC & DMB 24R
Date	MARCH 8 2005	Directory	3000		
Page		Levels	110		
File	AQ-3000 MASTER				

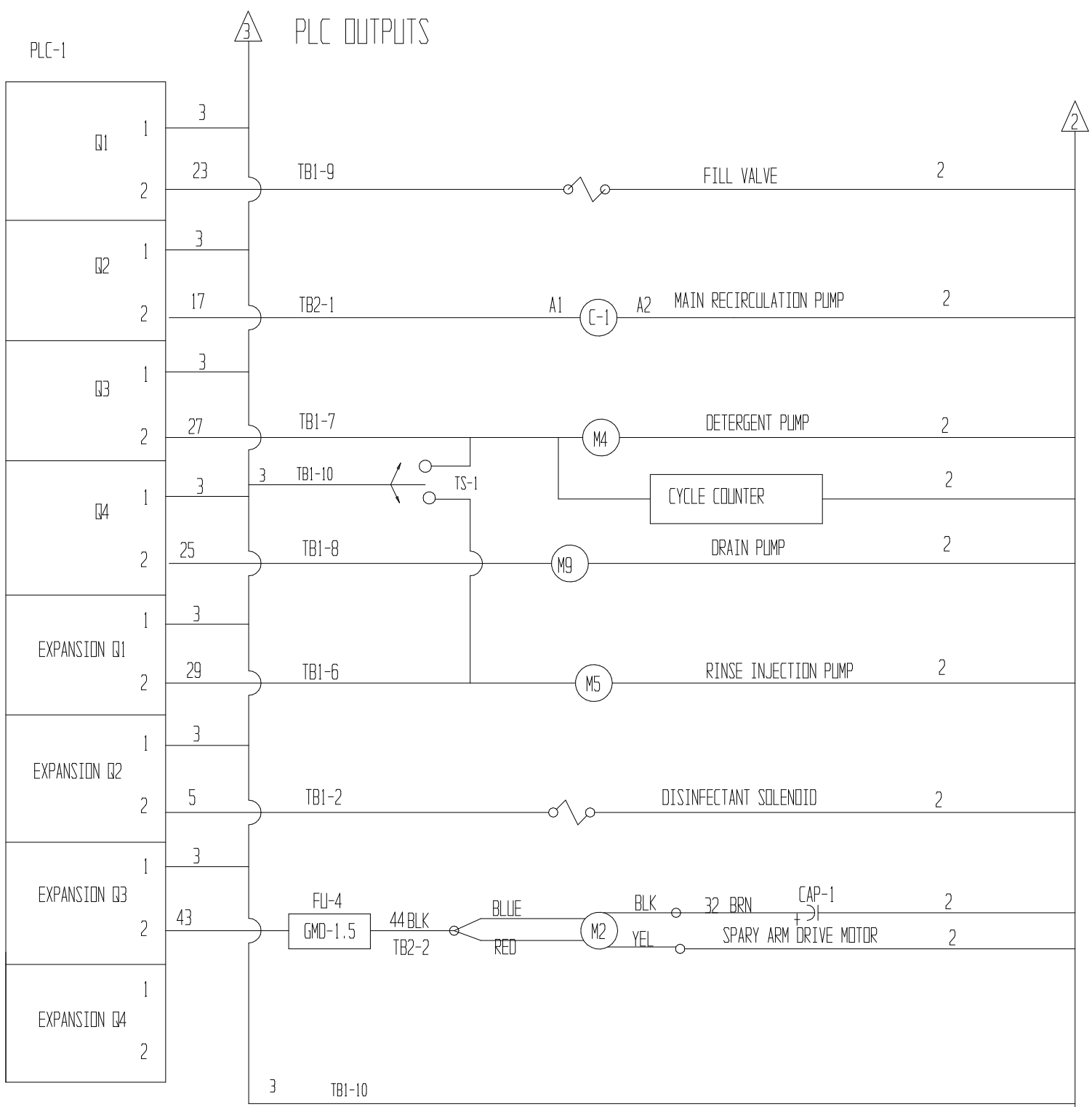

AQUA PHASE Operating Manual

Parker Brand 1/2" Valve - Black Electrical Coil

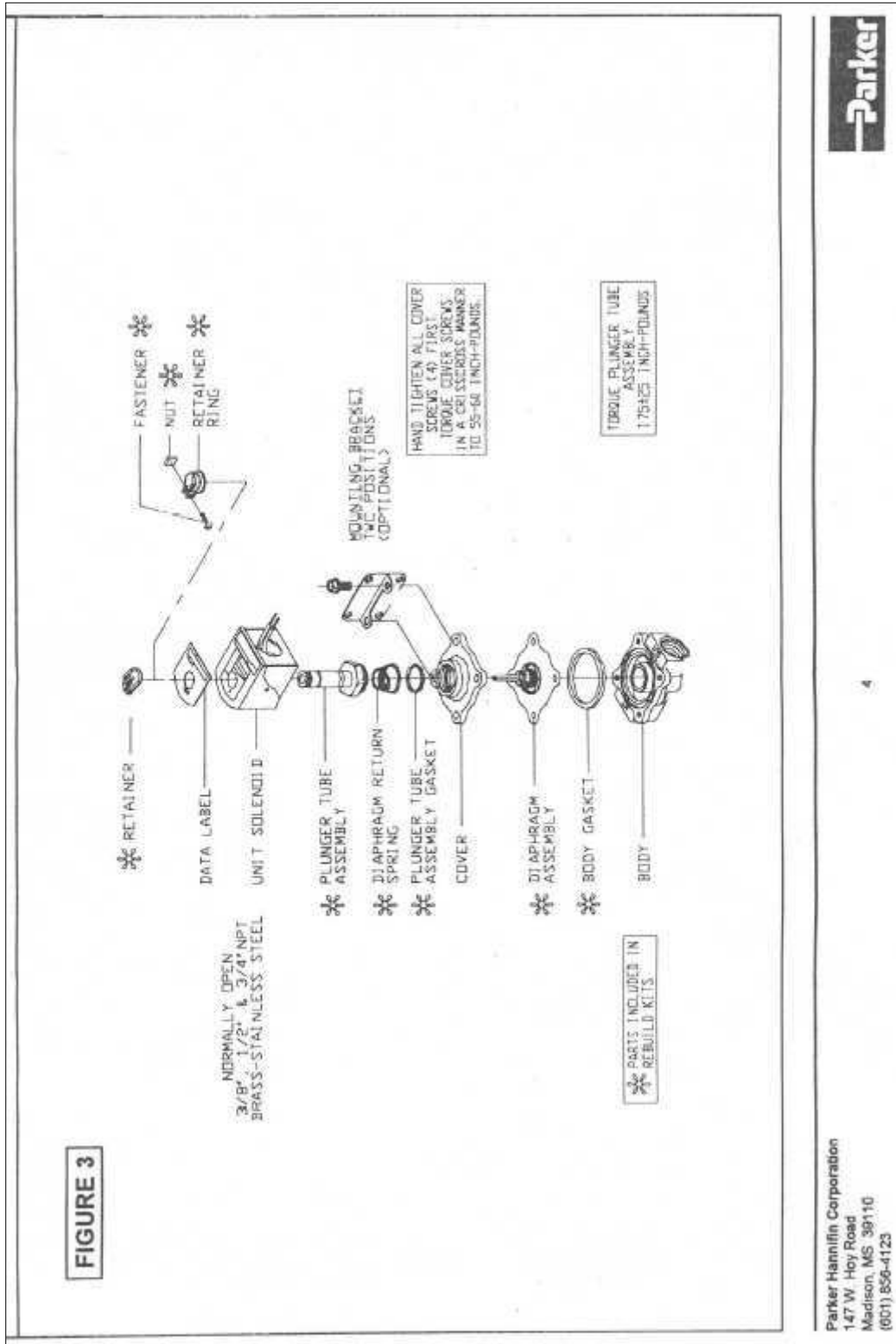

AQUA PHASE Operating Manual

ASCO Brand 1/2" and 1" Valve - Green Electrical Coil

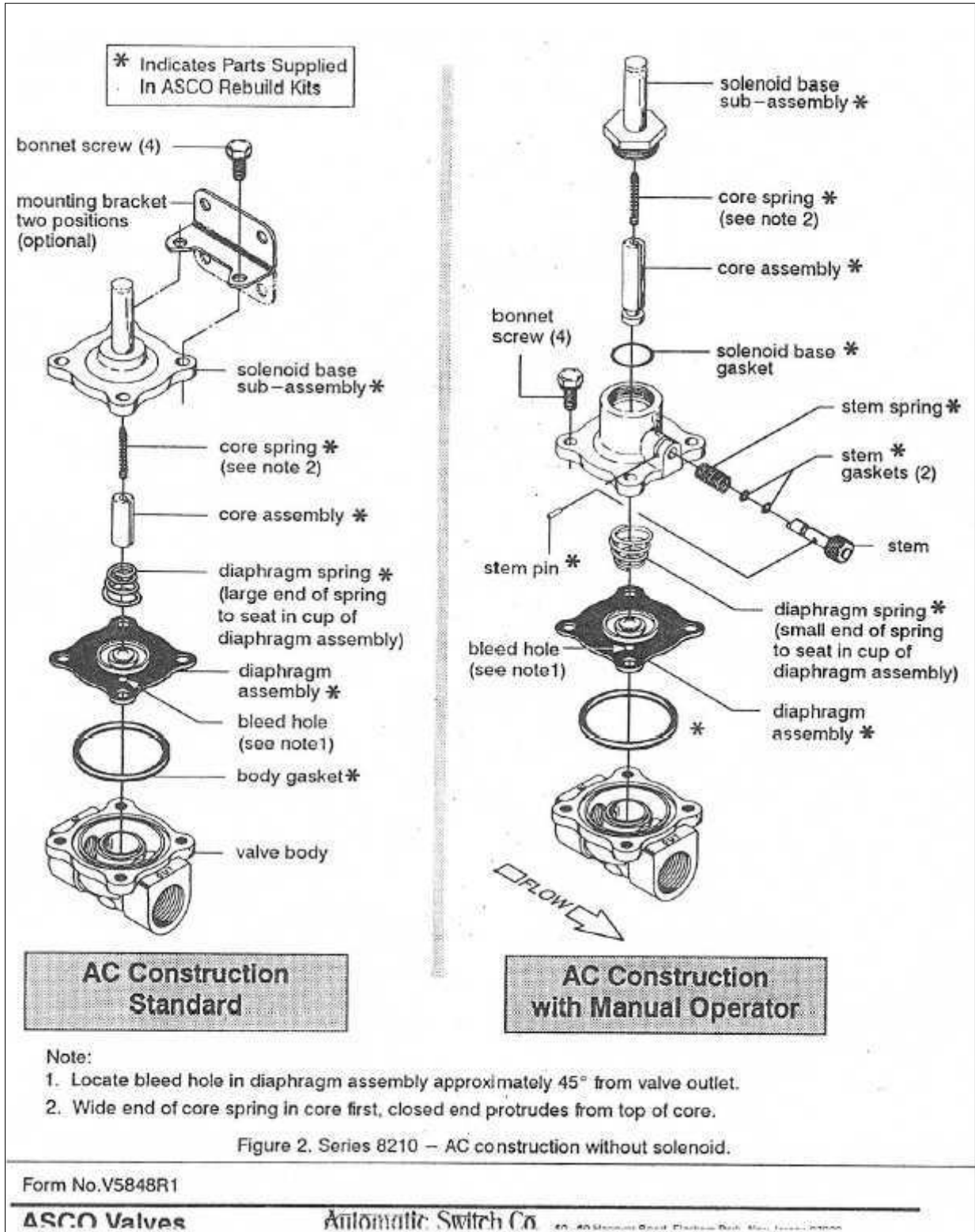

AQUA PHASE Operating Manual

Chemical Injection Pump Diagram

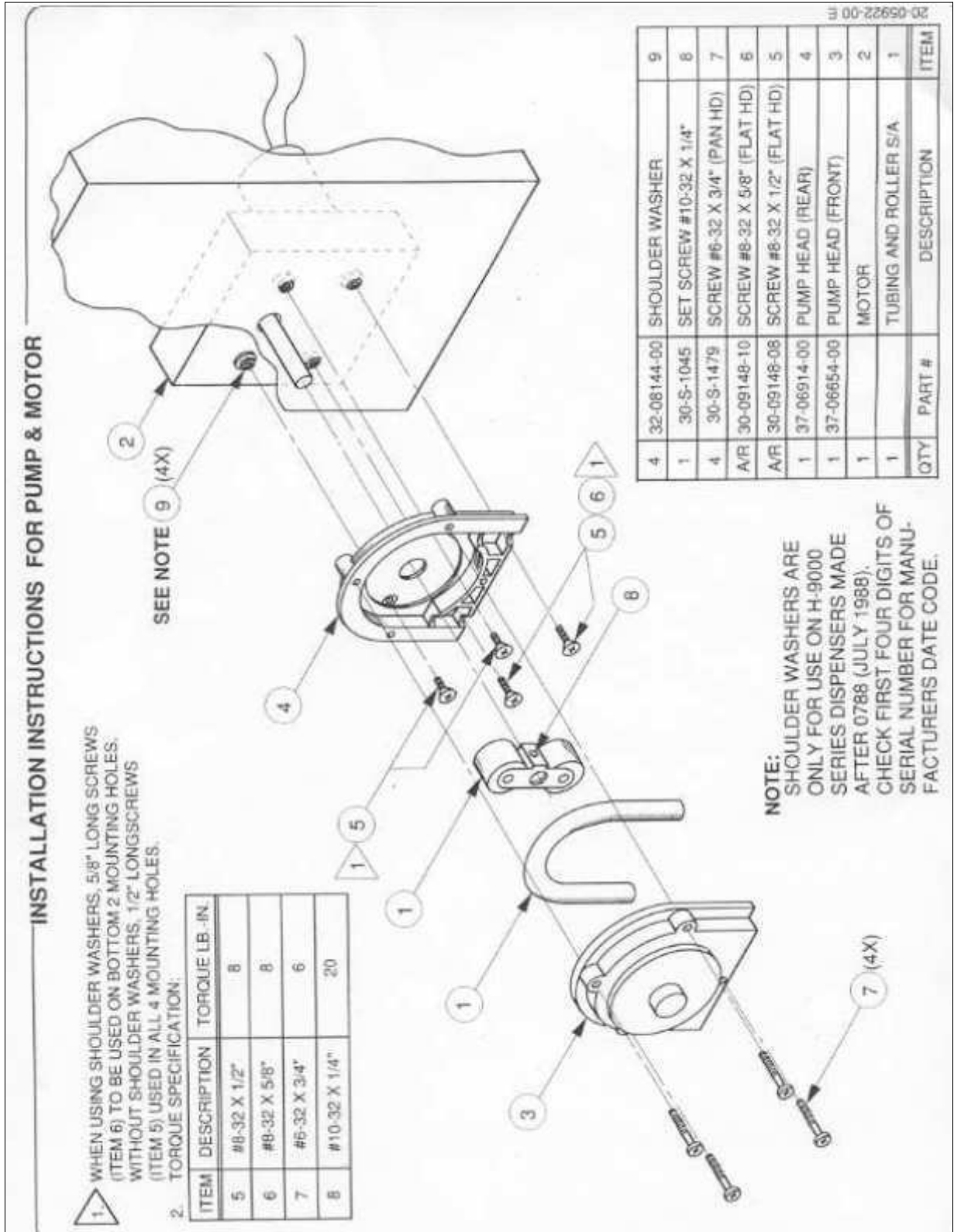

AQUA PHASE Operating Manual

Disinfectant Solution Injection Valve Diagram Page 1

DEMA SINGLE-STAGE INJECTOR MODELS 200-3C, 200C, 201C, 202C, 203C, 204C, 206C, 208C, 2012C

INSTALLATION INSTRUCTIONS

1. PARTS

- A. Injector.
- B. Drum protector disc.
- C. Three brass nozzle bushings.
- D. Plastic Tubing 8' long with foot strainer.
- E. Backup washer (Models 204C & smaller).

2. INSTALLATION

- A. Selecting the nozzle bushing:
Find the appropriate APPLICATION under Section 4 and use the tables to select one of the three bushings supplied. Push the bushing into the injector inlet, small end first, as far as it will go. See Fig. 1.
- B. Backup washer:
In some applications a flexible hose and shut off gun are used downstream from the injector. When the gun is shut off a momentary back flow can develop and push out the nozzle bushing. To prevent this, place the plastic backup washer behind the nozzle before screwing the injector onto the inlet pipe.
- C. Placement in the water line:
The injector may be installed in a horizontal or vertical line and with the knob in any position below, above, or to the side. Water flow must be in the direction of the arrow on the injector body. If the injector pipe size is different from the line size, use pipe bushings or reducers as required. (Injector selection is based on flow, not line size.)
- D. Connection to chemical supply:
Drop the end of the tubing with the strainer into the fluid product container. Cut the tubing to any convenient length and slip the open end over the injector fitting. The container may be more than 8 feet below the injector (extra tubing required) but injection capacity will be less. Do not place the container above the injector unless the injector is under pressure when not in use. This will prevent free siphoning.
The metal drum protector disc may be used to cover the container opening and to hold the tubing in place. Twist the disc at the slit for easy application.
The metal drum protector disc may be used to cover the container opening and to hold the tubing in place. Twist the disc at the slit for easy application.

3. CHEMICAL FEED ADJUSTMENT

See FIG. 1 for the location of the metering screw in the knob. The knob may be re-oriented for better accessibility by removing the 4 machine screws and turning it to the new position. Turn the metering screw to the left to increase the injection rate. Five turns provide the maximums shown in Table 1. These figures are with 5 feet of suction tubing, a lift of 4 feet from the fluid container to the injector, and for a maximum water temperature of 140°F. Injectors will operate at reduced injection rates up to 200°F or a lift up to 25 feet. If the chemical is viscous (above 75 cps) the maximum injection rates of injectors up to Model 204C can be as much as doubled by using 1/8" ID tubing. (Dema part 100-12L.) Use a 1" piece of regular tubing over the inlet barb as a bushing.
Optional "T" type metering knob (see parts list on back pages). Screw pre-selected metering tip (fixed orifice) into inlet barb before attaching plastic tubing.

4. APPLICATIONS

SPRAYING SYSTEM AT LINE PRESSURE FIGURES 3 AND 4.

Select the nozzle bushing to match your total spray nozzle flow and pressure as shown in Table 1 on page two. Spray nozzle catalog flow ratings are the most convenient method of determining water flow. Once an injector has been matched to a spray nozzle system, it will continue to function regardless of fluctuations in line pressure, as the water flow will also fluctuate in proportion. Therefore, if your line pressure is unknown, it is permissible to use spray nozzle ratings at any pressure for the purpose of selecting an injector. Flow ratings at 40 psi are the basis of the spray nozzle numbering system and are therefore most frequently used. If there are lengthy piping, hose, or other restrictions between the injector and nozzles, these pressure losses must be added to the rated pressure before entering Table 1 (see Table 12).

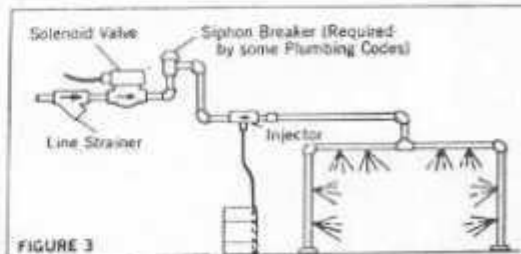
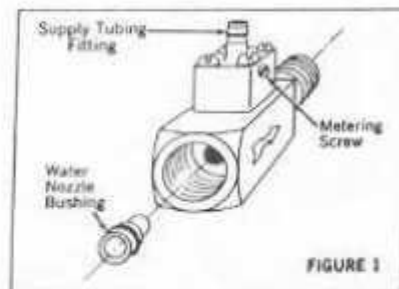

AQUA PHASE Operating Manual

Disinfectant Solution Injection Valve Diagram Page 2

SINGLE-STAGE INJECTORS

MODEL 200-3C, 200C, 201C, 202C, 203C 204C, 206C, 208C 2012C
MODEL #S MAY ALSO INCLUDE E, P, S, T, AND/OR -2

PART NO.	DESCRIPTION	PART NO.	DESCRIPTION
23-7	SCREW (1" LG. 4 REQ'D)	24-31-	BACK-UP WASHER (SPECIFY MODEL NO.)
23-8	WATER NOZZLE (BRASS) (ADD NUM. STAMPED ON NOZZLE)	24-32	METERING KNOB ASSY.
23-9	CHECK VALVE SPRING (STAINLESS)	24-32PS	METERING KNOB ASSY. (-P INJECTORS)
23-9-2	CHECK VALVE SPRING (HASTELLO Y)	24-32S	METERING KNOB ASSY.
23-10	CHECK VALVE BALL (STAINLESS)	24-32ST	METERING KNOB ASSY.
23-10P	CHECK VALVE BALL (TEFLON)	24-32T	METERING KNOB ASSY.
23-11	CHECK VALVE O-RING (EP)	24-33	SCREW #8-32 X 7/8 LG. (4 REQ'D)
23-11V	CHECK VALVE O-RING (VITON)	24-34	CHECK VALVE CORE (SPECIFY MODEL NO.)
23-24	METERING SCREW	24-8S-	WATER NOZZLE & O-RING ASSY. (STAINLESS) ADD NUM. STAMPED ON NOZZLE*
23-32	METERING KNOB ASSY.	25-29	METERING KNOB O-RING (EP)
23-32S	METERING KNOB ASSY.	25-29S	METERING KNOB O-RING (SILICONE)
23-32ST	METERING KNOB ASSY.	25-29V	METERING KNOB O-RING (VITON)
23-32T	METERING KNOB ASSY.	61-9-	METERING TIP (SPECIFY SIZE)
23-34-	CHECK VALVE CORE (SPECIFY MODEL NO.)	61-9K	METERING TIP KIT
24-8-	WATER NOZZLE & O-RING ASSY. (BRASS) ADD NUM. STAMPED ON NOZZLE*	61-107	CERAMIC WEIGHTS FOR 3/8" I.D. TUBING FOR 206C, 208C & 2012C
24-11L	FOOT STRAINER	61-107-2	CERAMIC WEIGHTS FOR 1/2" I.D. TUBING FOR 200-3C THRU 204C
24-11MP	FOOT STRAINER	61-9K	METERING TIP KIT
24-23	CHECK VALVE SPRING (STAINLESS)	100-12	VINYL TUBING (3/8" O.D. X 8' L.G.)
24-23-2	CHECK VALVE SPRING (HASTELLO Y)	100-12L	VINYL TUBING (1/2" O.D. X 8' L.G.)
24-24P	CHECK VALVE BALL (TEFLON)	100-15	METERING TIP (SPECIFY SIZE)
24-24S	CHECK VALVE BALL (STAINLESS)	100-15K	METERING TIP KIT
24-25	CHECK VALVE O-RING (EP)	100-24	METERING TIP KIT
24-25S	CHECK VALVE O-RING (SILICONE)	100-24PS	METERING SCREW (-P INJECTORS)
24-25V	CHECK VALVE O-RING (VITON)		

* ADD V TO END OF PART # FOR VITON O-RING

1-118
Rev. B 0600

AQUA PHASE Operating Manual

Fill Line Piping

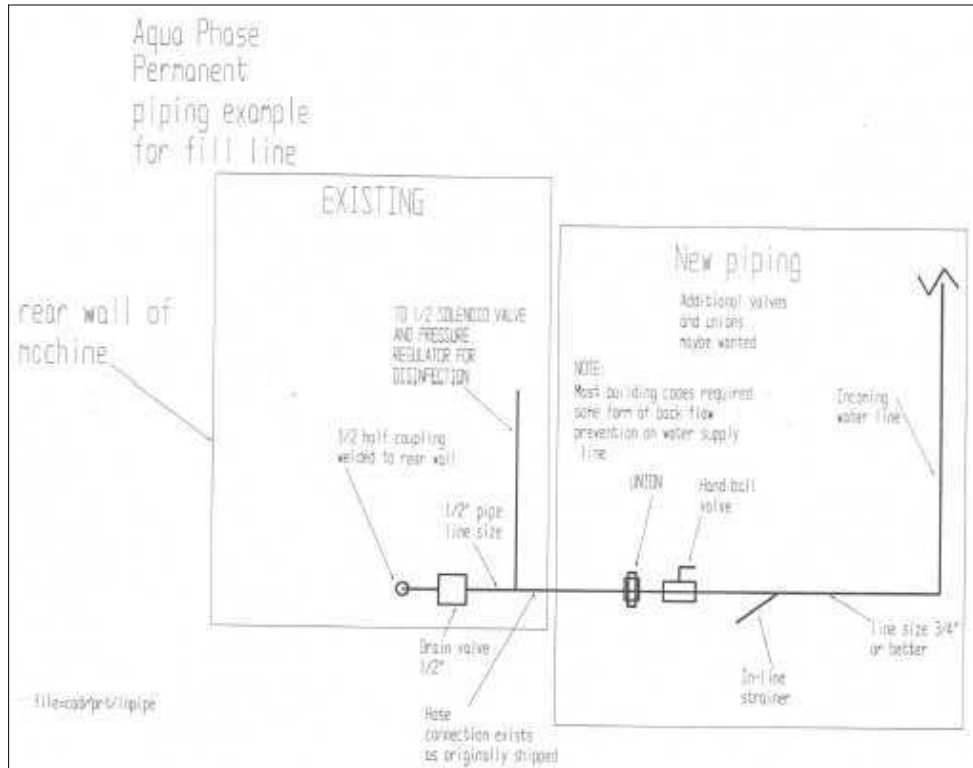

Drain Line Piping

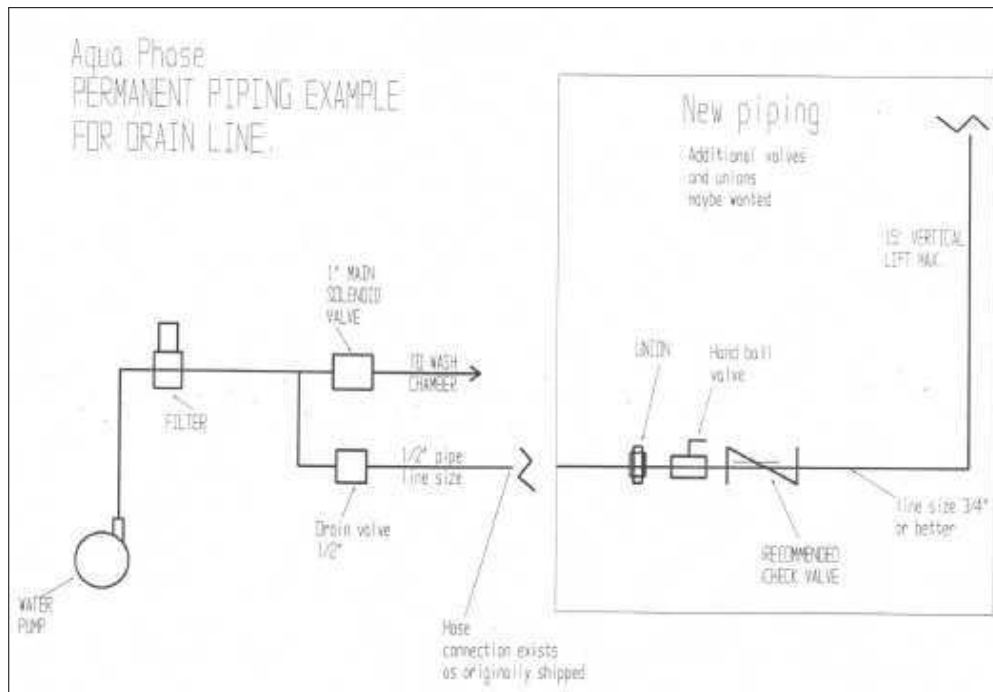

SECTION I **PRODUCT IDENTIFICATION -**
Product Name: AQUAPHASE AQ-240 CLEANING SOLUTION (P678) DOT Proper Shipping Name: Potassium hydroxide, solution, 8, UN 1814, II
Formula Type: Blended alkaline liquid

SECTION II **HAZARDOUS INGREDIENTS -**

Name	C.A.S. No.	%	Exposure Limit
Potassium hydroxide	1310-58-3	4-5	TWA 2 mg/m ³ (ceiling)

SECTION III **PHYSICAL DATA**
Appearance/Odor: Amber liquid/mild odor Solubility in Water: complete Evaporation Rate (butyl acetate=1): <1
Specific Gravity: 1.344 pH: 14 ± .2 Vapor Pressure (mm HG): NA
% Evaporation by Volume: 68 Boiling Point (F°): aprx 212 Vapor Density (air=1): NA

SECTION IV **FIRE AND EXPLOSION INFORMATION -**
Flashpoint (F°) (Method Used): Not flammable
Extinguishing media: foam CO₂ dry chemical water fog other XXX not applicable
Special fire fighting procedures: Use procedures proper for the primary source of the fire. Treat as an alkaline material.
Unusual fire and explosion hazard: Containers may melt or rupture from the heat of a fire.

SECTION V **HEALTH HAZARD DATA -** Primary routes of entry: eyes, skin, inhalation
Signs and symptoms -
Eye Contact: Direct contact can cause burns if not properly treated.
Skin Contact: Prolonged or repeated contact can cause severe irritation.
Inhalation: Spray mist or fog may cause irritation to nose, throat, or lungs if adequate ventilation is not provided.
Ingestion: May cause corrosive damage to mouth, throat or stomach.
Medical conditions generally aggravated by exposure: Pre-existing skin and lung diseases.

FIRST AID PROCEDURES -
Eye Contact: Immediately flush with cool running water for 15 minutes, while holding eyelids apart. Contact a physician immediately.
Skin Contact: Immediately wash with cool water for 15 minutes. Remove contaminated clothing. Contact physician if irritation persists.
Inhalation: Move to fresh air. Monitor breathing and treat symptomatically. Call a physician.
Ingestion: Do not induce vomiting. Drink 1-2 glasses of water or milk. Call a physician or poison control center immediately. Never give anything to drink to an unconscious person.

SECTION VI **REACTIVITY DATA -**
Stability: Stable
Incompatibility (materials to avoid): Oxidizers, acids, aluminum.
Hazardous decomposition products: Possibly CO₂ or hydrogen.
Hazardous polymerization: Will not occur

SECTION VII **SPILL LEAK PROCEDURES -**
Steps to be taken in case material is released or spilled: Wear protective equipment. Small spill: mop up and rinse area. Large spills: Dike spill. Absorb with inert material. Containerize. Rinse area with water. Keep out of storm sewers and waterways.
Waste disposal information: Properly neutralized liquid (pH 6 to 9) may be disposed of at a suitable facility in accordance with all federal, state and local regulations. Above pertains to undiluted product.

SECTION VIII **SPECIAL PROTECTION INFORMATION -**
Respiratory Protection: If mist is not controlled by local ventilation, use NIOSH respirators for organic vapors.
Ventilation: Central room or local exhaust.
Protective gloves: Rubber, pvc, nitrile
Eye Protection: Splash proof glasses or goggles.
Other protective measures: Rubber boots if there is a spill.

SECTION IX **SPECIAL PRECAUTIONS -**
Handling and Storage:
Keep container closed when not in use. Do not breathe mists or vapors. Keep out of reach of children. Mix only with water. For industrial & institutional use only. Wash contaminated clothing before reuse.

SECTION X **TOXICITY DATA -**
This product does not contain ingredients considered to be carcinogenic by the NTP, IARC, or OSHA.

SECTION XI **HAZARD RATING -** 0 = MINIMAL 1 = SLIGHT 2 = MODERATE 3 = SERIOUS 4 = SEVERE
Health: 3 Reactivity: 1 Fire: 0 Special: none

SECTION XII **REGULATORY INFORMATION -**

SECTION XIII **DOCUMENTARY INFORMATION -**
Date issued: 2/26/02 Supercedes: 3/30/99 Reason for update: review
The information contained herein is furnished without warranty of any kind. Employers should use this information only as a supplement to other information gathered by them and must make independent determinations of suitability and completeness of information from all sources to assure proper use of these materials and the safety and health of employees.

SECTION I PRODUCT IDENTIFICATION -

Product Name: AQ-260 DOT Proper Shipping Name: Cleaning Compound
Formula Type: Blended wetting agent

SECTION II HAZARDOUS INGREDIENTS -

Name	C.A.S. No.	%	Exposure Limit
Surfactant	9003-11-6	30	none

SECTION III PHYSICAL DATA

Appearance/Odor: Clear blue liquid/mild odor Solubility in Water: Moderate Evaporation Rate (butyl acetate=1):
Specific Gravity: 1.045 pH: 3.0 ± .2 Vapor Pressure (mm HG):
% Evaporation by Volume: 68 Boiling Point (F°): greater than 212 Vapor Density (air=1):

<1
Nil
NA

SECTION IV FIRE AND EXPLOSION INFORMATION -

Flashpoint (F°) (Method Used): Greater than 450°F C.O.C.
Extinguishing media: foam CO₂ dry chemical water fog other not applicable
Special fire fighting procedures: Should be equipped with self contained breathing apparatus and turn out gear.
Unusual fire and explosion hazard: Containers may melt or rupture from the heat of a fire.

SECTION V HEALTH HAZARD DATA - Primary Routes of Entry: Eyes, skin and inhalation.

Signs and symptoms -

Eye Contact: Direct contact of product may cause irritation.
Skin Contact: Prolonged or repeated skin contact may result in irritation or redness.
Inhalation: Essentially no vapors at normal room temperature.
Ingestion: Causes diarrhea, weakness, irritation of mouth and throat.
Medical conditions generally aggravated by exposure: None known.

FIRST AID PROCEDURES -

Eye Contact: Immediately flush with cool running water for 15 minutes, while holding eyelids apart. Obtain medical attention if irritation develops.
Skin Contact: Wash with water. Obtain medical attention if irritation develops.
Inhalation: Remove to fresh air. Obtain medical attention.
Ingestion: If conscious, drink several glasses of water. Induce vomiting. Obtain immediate medical attention. If unconscious, do not give anything to drink, do not induce vomiting, and immediately obtain medical aid.

SECTION VI REACTIVITY DATA -

Stability: Stable
Incompatibility (materials to avoid): Strong oxidizers and alkalis
Hazardous decomposition products: SO₂
Hazardous polymerization: will not occur

SECTION VII SPILL LEAK PROCEDURES -

Steps to be taken in case material is released or spilled: Small spills: Mop up and rinse area with water. Large spills should be contained, absorbed and placed in suitable containers for disposal. Spill area will be very slippery! Wear protective equipment.
Waste disposal information: Consult federal, state, and local regulations. May be able to incinerate or bury in a licensed facility. Do not discharge into waterways or sewer systems.

SECTION VIII SPECIAL PROTECTION INFORMATION -

Respiratory Protection: Essentially no vapors at normal room temperature. No TLV established.
Ventilation: Local exhaust.
Protective gloves: Rubber gloves to avoid repeated or prolonged contact.
Eye Protection: Chemical splash proof glasses or goggles if possibility of eye contact.
Other protective measures: A source of water that can be used to wash eyes in case of contact.

SECTION IX SPECIAL PRECAUTIONS -

Handling and Storage:
Keep container closed when not in use. For industrial and institutional use only. Keep out of reach of children. Keep from freezing. Do not store above 110°F. Do not breathe mist or vapors. Mix only with water. Wash contaminated clothing before reuse.

SECTION X TOXICITY DATA -

SECTION XI HAZARD RATING - 0 = MINIMAL 1 = SLIGHT 2 = MODERATE 3 = SERIOUS 4 = SEVERE

Health: 0 Reactivity: 0 Fire: 0 Special: none

SECTION XII REGULATORY INFORMATION -

SECTION XIII DOCUMENTARY INFORMATION -

Date issued: 2/26/02 Supercedes: 3/29/99 Reason for update: review

The information contained herein is furnished without warranty of any kind. Employers should use this information only as a supplement to other information gathered by them and must make independent determinations of suitability and completeness of information from all sources to assure proper use of these materials and the safety and health of employees.

SECTION I **PRODUCT IDENTIFICATION - Ag-280**

Product Name: Rust Inhibitor DOT Proper Shipping Name: Cleaning compound
Formula Type: Blended amine liquid

SECTION II **HAZARDOUS INGREDIENTS -**

Name	C.A.S. No.	%	Exposure Limit
2-Butoxy Ethanol	111-76-2	5-10	20 ppm skin PEL & TLV
Isopropyl Alcohol	67-63-0	5-10	400 ppm
Amine Salt	no CAS #	20-30	None established

SECTION III **PHYSICAL DATA**

Appearance/Odor:	Clear amber/solvent odor	Solubility in Water:	complete	Evaporation Rate (butyl acetate=1):	= water
Specific Gravity:	.876	pH:	6.4 ± .2	Vapor Pressure (mm HG):	.1 @ 68° F ma
% Evaporation by Volume:	> 75	Boiling Point (F°):	aprx 200	Vapor Density (air=1):	> 1

SECTION IV **FIRE AND EXPLOSION INFORMATION -**

Flashpoint (F°) (Method Used): 130° TOC
Extinguishing media: x foam CO₂ x dry chemical x water fog other not applicable
Special fire fighting procedures: Use procedure proper for the primary source of the fire.
Unusual fire and explosion hazard: Containers may rupture or melt from the heat of a fire. No unusual combustion products.

SECTION V **HEALTH HAZARD DATA - PRIMARY ROUTES OF ENTRY: Eyes, skin, ingestion.**

Signs and symptoms -
Eye Contact: Can cause irritation and may injure eye tissue if eyes are not promptly washed.
Skin Contact: Frequent or prolonged contact may irritate and cause dermatitis.
Inhalation: Generally not a hazard. Excessive inhalation may cause dizziness or irritation to respiratory tract.
Ingestion: Nausea, stomach pain, irritant to mouth, throat and stomach.
Medical Conditions generally aggravated by exposure: Pre-existing skin disorders.

FIRST AID PROCEDURES -

Eye Contact: Immediately flush with cool water for 15 minutes while holding eyelids apart. If irritation develops, obtain medical attention.
Skin Contact: Immediately flush with cool water. If irritation develops, obtain medical attention. Remove and wash contaminated clothing.
Inhalation: Remove to fresh air. Obtain medical aid if symptoms persist.
Ingestion: Do NOT induce vomiting. Drink several glasses of water. Obtain medical attention. If unconscious, do not give anything to drink, and do NOT induce vomiting. Obtain immediate medical aid.

SECTION VI **REACTIVITY DATA -**

Stability: Stable
Incompatibility (materials to avoid): Acids and oxidizers
Hazardous decomposition products: none
Hazardous polymerization: will not occur.

SECTION VII **SPILL OR LEAK PROCEDURES -**

Steps to be taken in case material is released or spilled: Small spills: Mop up and rinse with water. Wear protective equipment. Large spills: Dike with earth or sand to prevent liquid from entering sewer and waterways. Salvage liquid if possible. Absorb remainder. Shovel into containers for waste disposal.
Waste disposal information: Dispose in conformance to all local, state and federal regulations. Consult local EPA if product enters waterways.

SECTION VIII **SPECIAL PROTECTION INFORMATION -**

Respiratory Protection: Not needed when used according to directions. If TLV is exceeded wear NIOSH approved respirator for organic vapors.
Ventilation: General, local.
Protective gloves: Rubber, or nitrile if there is skin contact.
Eye Protection: Goggles or splash proof glasses.
Other protective measures: Rubber boots if there is a spill.

SECTION IX **SPECIAL PRECAUTIONS -**

Handling and Storage:
Keep container closed when not in use. For industrial and institutional use only. Keep out of reach of children. Keep from freezing. Storage temperature: Ambient to 120 ° F. Other precautions: Wash contaminated clothing before reuse.

SECTION X **TOXICITY DATA -**

Product does not contain ingredients considered to be carcinogenic by NTP, IARC, or OSHA. 2 Butoxy Ethanol : Over exposure has apparently been found to cause the following effects in laboratory animals: anemia, liver abnormalities, kidney damage, lung damage, blood abnormalities.

SECTION XI **HAZARD RATING - 0 = MINIMAL 1 = SLIGHT 2 = MODERATE 3 = SERIOUS 4 = SEVERE**

Health: 1 Reactivity: 0 Fire: 2 Special: none

SECTION XII **REGULATORY INFORMATION -**

2-Butoxy ethonal is subject to reporting requirements of section 313 of Title III SARA.

SECTION XIII **DOCUMENTARY INFORMATION -**

Date issued: 6/16/98 Supercedes: 12/21/94 Reason for update: Section II
The information contained herein is furnished without warranty of any kind. Employers should use this information only as a supplement to other information gathered by them and must make independent determinations of suitability and completeness of information from all sources to assure proper use of these materials and the safety and health of employees.

MATERIAL SAFETY DATA SHEET**EMERGENCY PHONE**
1-800-255-3924
1-612-672-0022**SECTION 1: PRODUCT IDENTIFICATION**

TRADE NAME	PRODUCT TYPE	CODE IDENTIFICATION
Deliming Solution	Acid Blend	#515

DOT SHIPPING NAME: Corrosive Liquid, Acidic, Inorganic, N.O.S., (contains: Phosphoric Acid), 8, UN3264, PGIII (quart commodities and under = ORM-D or Limited Quantity)**SECTION 2: HAZARDOUS INGREDIENTS**

	CAS NUMBER	%	EXPOSURE CRITERIA
Phosphoric Acid (H3P04)	7664-38-2	30-60	1 mg/m3
Hydroxyacetic Acid	000079-14-1	0-5	Not Established

NFPA Hazard Signal:

HMIS:

4=Extreme

Health= 3

DOT Hazard Class: Corrosive Material

3=High

Stability= 0

EPA Hazard Waste Class: Corrosive Material

2=Moderate

Flammability= 0

1=Slight

Special=None

0=Insignificant

SECTION 3: PHYSICAL DATA

Boiling Point: 760 mm Hq: 212F

Melting Point: N/A

Freezing Point: N/A

Vapor Pressure @ : Similar to water

Specific Gravity (Water=1): N/A

Solubility in Water: Complete

Vapor Density (AIR=1): N/A

Evaporation Rate (BuAc=1): <1

% Volatiles By Volume:

pH of 1%: 1.7

Appearance & Odor: Clear, colorless liquid; None

SYMPTOMS AND EFFECTS OF EXPOSURE:

EYES: Causes burns of any exposed tissue.

SKIN: Causes burns to any exposed tissue.

INGESTION: Irritant, slightly toxic when ingested.

INHALATION: Irritant, slightly toxic when inhaled.

MATERIAL SAFETY DATA SHEET (continued)

SECTION 4: FIRE & EXPLOSION HAZARD DATA

FLASH POINT (& METHOD USED)	FLAMMABLE LIMITS IN AIR % BY VOLUME	AUTO IGNITION TEMPERATURE
N/A	Lower N.A. Upper N.S.	

EXTINGUISHING MEDIA: Not flammable or combustible.

SPECIAL FIRE FIGHTING PROCEDURES: Use full protective clothing and self-contained breathing apparatus.

UNUSUAL FIRE AND EXPLOSION HAZARD: Thermal decomposition emits toxic fumes or oxides or phosphorous.

SECTION 5 REACTIVITY DATA

STABILITY (Normal Conditions): Stable Conditions to Avoid: Reaction with some metals may produce Hydrogen gas which is explosive with air and a spark.

INCOMPATIBILITY (Materials to Avoid): Alkali (bases); Reactive metals (mild steel, aluminum), cyanides, sulfites or nitrites.

HAZARDOUS DECOMPOSITION PRODUCTS: At flame temperatures, can emit toxic phosphorous oxide fumes.

HAZARDOUS POLYMERIZATION: Will not occur.

SECTION 6: HEALTH HAZARD INFORMATION

TOXITY INFORMATION:

EFFECTS OF OVEREXPOSURE: Acute -- Irritant, slightly toxic when inhaled or ingested.

Chronic: Slightly toxic with repeated inhalation or ingestion. Causes burns to any exposed tissue.

EMERGENCY AND FIRST AID PROCEDURES:

EYE: Flush copiously and immediately with running water for 15 minutes. SEEK MEDICAL ATTENTION.

SKIN: Flush copiously and immediately with running water for 15 minutes. SEEK MEDICAL ATTENTION.

INGESTION: SEEK MEDICAL ATTENTION.

INHALATION: Remove to fresh air. If irritation persists, seek medical attention.

COMMENTS: N.A. = NOT APPLICABLE N.D. = NOT DETERMINED

MATERIAL SAFETY DATA SHEET (continued)

SECTION 7: SPECIAL PROTECTION INFORMATION

Ventilation Requirements: General mechanical ventilation desirable.

Respiratory Protection (Specify Type): For severe vapor or mist, use NIOSH certified self-contained air pack.

Eye Protection: Chemical safety goggles or face shield & goggles.

Gloves: Rubber or neoprene.

Other Protective Clothing and Equipment: Where contact is likely, rubber apron and boots.

SECTION 8: SPILL OR LEAK PROCEDURES

Steps To Take If Material Is Released Or Spilled: Dike and neutralize. Keep in separate waste containers. After neutralization, landfill should normally be suitable, but check with federal, state and local codes. Dispose according to environment regulations.

SECTION 9: SPECIAL PRECAUTIONS

Precautions To Be Taken In Handling And Storage: Store in cool, dry, well ventilated location.

OTHER PRECAUTIONS: Store in suitable containers only (glass, fiberglass, polyethylene lined drums or 316ss).

REVIEWED BY: _____ DATE: 2/26/02
Dick Anderson

The information accumulated herein is believed to be accurate but is not warranted to be whether originating with manufacturer or not. Recipients are advised to confirm in advance of need that the information is current, applicable, and suitable to their circumstances.

Mid States Stainless, Inc.
330 W. Benson Ave.
Grantsbukrg, WI 54840

VIREX II 128 - USE DILUTION

National Fire Protection Association (NFPA)	Fire Hazard	Hazardous Material Information System (HMIS)	Health	1
	Health		1	0
	Reactivity		0	0
	Specific Hazard			
Protective Clothing	None required.	Emergency Overview	Colorless. Liquid. See Section 9. CAUTION: May be mildly irritating to eyes. May be mildly irritating to skin.	

Section 1. Chemical Product and Company Identification

Product Name	VIREX II 128 - USE DILUTION	Code	113785D
Product Use	Industrial/Institutional: Cleaning product.	PMS#	Not available.
MSDS#	113785/1-DIL	Validation Date	12/17/2002
U.S. Headquarters	Johnson Wax Professional 8310 16th Street Sturtevant, Wisconsin 53177-0902 Phone: (888) 352-2249 MSDS Internet Address: www.jwp.com	Canadian Headquarters	Johnson Wax Professional 100 Matheson Blvd. East, Suite 203 Mississauga, Ontario L4Z 2G7 Phone: (905) 755-0913 or (888) 746-5971
		Print Date	12/17/2002
		Supersedes	No Previous Validation.
		In Case of Emergency	(800) 851-7145

Section 2. Composition and Information on Ingredients

Ingredients	CAS #	% by Weight	Exposure Limits	LC50/LD50
n-Alkyl Dimethyl Benzyl Ammonium Chloride	139-08-2	<1	Not available.	ORAL (LD50): Acute: 426 mg/kg [Rat].
Water	7732-18-5	60-100	Not available.	Not available.

Section 3. Hazards Identification

Routes of Entry	Inhalation. Skin contact. Eye contact. Ingestion.
Potential Acute Health Effects	
<i>Eyes</i>	May be mildly irritating to eyes.
<i>Skin</i>	May be mildly irritating to skin.
<i>Inhalation</i>	None known.
<i>Ingestion</i>	May cause abdominal discomfort, nausea, vomiting and diarrhea.
Medical Conditions Aggravated by Overexposure:	Persons with pre-existing skin disorders may be more susceptible to irritating effects.
See Toxicological Information (section 11)	

Section 4. First Aid Measures

Eye Contact	Flush immediately with plenty of water. Get medical attention if irritation occurs.
Skin Contact	Flush immediately with plenty of water. Get medical attention if irritation occurs.
Inhalation	If breathing is difficult: Seek medical attention. Remove to fresh air.
Ingestion	Immediately drink plenty of water. If discomfort persists, get medical attention.

Section 5. Fire Fighting Measures

Flammability of the Product	None known.
Flash Points	Not available.
Products of Combustion	None known.
Fire Fighting Media and Instructions	Extinguish with water spray or carbon dioxide, dry chemical powder or appropriate foam. Normal fire fighting procedure may be used.
Special Remarks on Fire and Explosion Hazards	None known.

Section 6. Accidental Release Measures

Personal Precautions	Put on appropriate personal protective equipment (see Section 8).
Environmental Precautions and Clean-up Methods	In the event of major spillage: Use appropriate containment to avoid environmental contamination. Sweep or scrape up material. Place in suitable clean, dry containers for disposal by approved methods. Use a water rinse for final clean-up.

Section 7. Handling and Storage

Handling	Avoid contact with skin and eyes. FOR INDUSTRIAL USE ONLY
Storage	Store in a dry, cool and well-ventilated area. Protect from freezing. KEEP OUT OF REACH OF CHILDREN.

Section 8. Exposure Controls/Personal Protection

Engineering Controls No special ventilation requirements. General room ventilation is adequate.

Personal Protection

Eyes No special protective clothing is required.

Hands No special protective clothing is required.

Respiratory No special protective clothing is required.

Feet No special protective clothing is required.

Body No special protective clothing is required.

Section 9. Physical and Chemical Properties

Physical State and Appearance	Liquid.
Odor	Characteristic.
Color	Colorless.
pH	9 to 10 [Basic.]
Specific Gravity	1
Boiling/Condensation Point	>93°C (199.4°F)
Melting/Freezing Point	0°C (32°F)
Solubility in water	Complete.

Section 10. Stability and Reactivity

Stability and Reactivity	The product is stable.
Conditions of Instability	None known.
Incompatibility with Various Substances	None known.
Hazardous Decomposition Products	When exposed to fire: Produces normal products of combustion.
Hazardous Polymerization	Will not occur.

Section 11. Toxicological Information

Acute toxicity ORAL (LD50) Estimated to be greater than 5000 mg/kg (rat).

Effects of Chronic Exposure None known.

Other Toxic Effects Not available.

Section 12. Ecological Information

Not available.

Section 13. Disposal Considerations

Waste Information No special precautions. Dispose of according to all federal, state and local regulations.

Section 14. Transport Information

DOT Classification

Not regulated

TDG Classification

Not regulated

Section 15. Regulatory Information

Reporting in this section is based on ingredients disclosed in Section 2

US Regulations

This product is not subject to the reporting requirements under California's Proposition 65.

Registered Product Information Not applicable.

Canadian Regulations

WHMIS Classification Not controlled under WHMIS (Canada).

WHMIS Icon

Registered Product Information Not applicable.

Chemical Inventory Status All ingredients of this product are listed or are excluded from listing on the U.S. Toxic Substances Control Act (TSCA) Chemical Substance Inventory.

Section 16. Other Information

Other Special Considerations Not available.

Version 1

Notice to Reader

This document has been prepared using data from sources considered technically reliable. It does not constitute a warranty, express or implied, as to the accuracy of the information contained within. Actual conditions of use and handling are beyond seller's control. User is responsible to evaluate all available information when using product for any particular use and to comply with all Federal, State, Provincial and Local laws and regulations.



Spartan Chemical Company, Inc.

Material Safety Data Sheet

SECTION I: PRODUCT INFORMATION

Product Name or Number (as it appears on label):

TB-CIDE PLUS

Product Number: 1023

Spartan Chemical Company, Inc.**1110 Spartan Drive****Maumee OH 43537**

Product Division:

JanitorialProduct/Technical
Information: **1-(800)-537-8990**Medical Emergency: **1-(888)-314-6171 (24 hours)**Chemical Leak/Spill
Emergency: **CHEMTREC 1-(800) 424-9300 (24 hours)**

Shipping Description:	Flammable liquids, corrosive, n.o.s., 3, UN 2924, III, (contains isopropanol, ortho-benzyl para-chlorophenol)
-----------------------	---

NFPA Ratings:		HMIS Ratings:	
Health:	3 - Serious	Health:	3 - Serious
Fire:	2 - Moderate	Fire:	2 - Moderate
Reactivity:	0 - Minimal	Reactivity:	0 - Minimal
		Pers. Prot. Equip.:	See Section VIII

SECTION II: HAZARDOUS INGREDIENTS

(Listed when present at 1% or greater, carcinogens at 0.1% or greater) All component chemicals are listed or exempted from listing on the "TSCA Inventory" of chemical substances maintained by the U.S. Environmental Protection Agency.

Chemical Name(s)	% W	CAS Registry No.	Table Z- 1 - A			NTP, IARC or OSHA Carcinogen
			TWA mg/m ³	STEL mg/m ³	CEILING mg/m ³	
Para-tertiary-amyphenol	5-10	80-46-6	Not Established	Not Established	Not Established	No
Ortho benzyl-para-chlorophenol	5-10	120-32-1	Not Established	Not Established	Not Established	No
*Ortho phenyl phenol	5-10	90-43-7	1 (Dow)	Not Established	Not Established	No
Isopropanol	5-10	67-63-0	980	1225	Not Established	No
Sodium hydroxide	5-10	1310-73-2	2	Not Established	Not Established	No

Comment: *This substance is subject to the reporting requirements of Section 313 of the Emergency Planning and Community Right-To-Know Act of 1986 (SARA) and of 40 CFR 372.

SECTION III: PHYSICAL DATA

Boiling Point:	212 °F	Vapor Pressure:	Unknown
Vapor Density (AIR = 1):	Unknown	Solubility in Water:	Complete
pH:	11.5-12.5	Specific Gravity (H ₂ O=1):	1.07
Evaporation Rate (but.ace.=1):	<1	Percent Solid by Weight:	50-55
Physical State:	Liquid		
Appearance & Odor:	Dark amber to purple, light lemon fragrance		

SECTION IV: FIRE & EXPLOSIVE HAZARD DATA

Flash Point:	(Tag Closed Cup) 118°F	Method Used:	ASTM-D56
Flammable Limits:	N/A	Flame Extension:	N/A
Extinguishing Media:	Water, foam, carbon dioxide		
Special Fire Fighting Procedures:	Wear NIOSH approved self-contained breathing apparatus and protective clothing. Cool fire-exposed containers with water spray.		
Unusual Fire & Explosive Hazards:	Products of combustion are toxic.		

SECTION V: HEALTH HAZARD DATA

Threshold Limit Value:	Not Established	Primary Routes of Entry:	Inhalation, Skin Contact, Eyes and Oral
Effects of Overexposure- Conditions to Avoid:	<p>CORROSIVE: CAUSES IRREVERSIBLE EYE DAMAGE: Symptoms may include pain, redness, swelling of the conjunctiva and tissue damage. CAUSES SKIN BURNS: Symptoms may include pain, redness and tissue destruction. Harmful if absorbed through the skin. HARMFUL IF SWALLOWED: Symptoms may include nausea, vomiting, pain and diarrhea. INHALATION OF SPRAY MIST MAY CAUSE HARM OR IRRITATION: Breathing spray mist may cause coughing and difficulty breathing. Do not get in eyes, on skin or clothing. Do not taste or swallow. Avoid inhalation of spray mist. Wash thoroughly with soap and water after handling and before eating, drinking or using tobacco.</p>		
Conditions Aggravated by Use:	Use of this product may aggravate preexisting skin; eye and respiratory disorders including asthma and dermatitis.		

Emergency & First Aid Procedures:

Eyes:	Hold eye open and rinse slowly and gently with water for 15-20 minutes. Remove contact lenses; if present; after the first five minutes; then continue rinsing eye.
Skin:	Take off contaminated clothing. Rinse skin immediately with plenty of water for 15-20 minutes. Call a poison control center or doctor for treatment advice. Wash contaminated clothing before reuse.
Ingestion:	Call a poison control center or doctor immediately for treatment advice. Have person sip glass of water if able to swallow. Do not induce vomiting unless told to do so by a poison control center or doctor. Do not give anything by mouth to an unconscious person. Avoid alcohol.
Inhalation:	Remove individual to fresh air.

▼ **SECTION VI: REACTIVITY DATA**

Stability:	Stable	Incompatible Materials:	Acids; other detergents; chlorine
Hazardous Decomposition Products:	CO, CO ₂	Hazardous Polymerization:	Will Not Occur

▼ **SECTION VII: SPILL OR LEAK PROCEDURES**

Steps to be Taken in Case Material is Released or Spilled:	Dike and contain spill with inert material (sand, earth, commercial absorbent, etc.) and transfer to containers for disposal. Rinse area with water and flush to sanitary sewer. Keep spill out of storm sewers and waterways.
Waste Disposal Method:	Dispose of in compliance with all federal, state and local laws and regulations.

▼ **SECTION VIII: SPECIAL PROTECTION INFORMATION**

Respiratory Protection:	Not normally required when good general ventilation is provided. However, if exposure limits (see Section II) are exceeded or if respiratory irritation occurs, use of a NIOSH approved respirator suitable for the use-conditions and chemicals in Section II should be considered.
Ventilation:	Provide good general ventilation. Local exhaust ventilation may be necessary for some operations.
Protective Gloves(Specify Type):	Nitrile rubber, Neoprene rubber or other impervious gloves are recommended to prevent skin contact.
Eye Protection(Specify Type):	Splash Goggles or face shield are recommended to prevent eye contact.
Other Protective Equipment:	Long sleeve shirt and long pants. Socks and shoes. Eye wash stations and washing facilities should be readily accessible in areas where undiluted product is handled.. See 29 CFR 1910.132-138 for further guidance.

▶ **SECTION IX: SPECIAL PRECAUTIONS**

© SCC 06/01/2004
TB-CIDE PLUS

Name: Ronald T. Cook
Effective 06/01/2004
Date:

Title: Manager, Regulatory Affairs
Supersedes: 01/01/2002

Ref: 29 CFR 1910.1200 (OSHA) Changes: Update Sections II, IV, V, VIII & IX

This document has been prepared using data from sources considered technically reliable. It does not constitute a warranty, express or implied, as to the accuracy of the information contained herein. Actual conditions of use and handling are beyond sellers control. User is responsible to evaluate all available information when using product for any particular use and to comply with all Federal, State and Local laws and regulations.